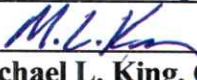

ELKTON POLICE DEPARTMENT		GENERAL ORDERS	
SUBJECT: AUTOMATED LICENSE PLATE RECOGNITION SYSTEM		NUMBER: 3-33	
EFFECTIVE DATE: January 2, 2026		REVIEW DATE: Annually	
AMENDS/SUPERSEDES:		APPROVED:  Michael L. King, Chief of Police	
CALEA STANDARDS:		VLEPSC STANDARDS:	

NOTE

This order is for internal use only, and does not enlarge an officer's civil or criminal liability in any way. It should not be construed as the creation of a higher standard of safety or care in an evidentiary sense, with respect to third-party claims. Violations of this directive, if proven, can only form the basis of a complaint by this department, and then only in a non-judicial administrative setting.

POLICY INTRODUCTION:

The Elkton Police Department utilizes automatic license plate recognition system (hereafter referred to as ALPR). ALPR is defined as a system of one or more high-speed cameras used in combination with computer algorithms to convert images of license plates, vehicles, or a combination of both into computer-readable data. Automated license plate recognition improves efficiency and reduces the time needed to complete tasks in which vehicle identification is necessary. Modern ALPR systems deliver high levels of accuracy, even in adverse weather conditions, in various settings.

PURPOSE:

The purpose of this General Order is to establish administrative and operational guidelines for the acceptable use of ALPR systems that shall not conflict with 2.2-5517, Code of Virginia.

PROCEDURES:

- A. The use of and/or access to an LPR system is restricted to official purposes only. An ALPR system shall be used for official law enforcement purposes only and in compliance with §2.2-5517, Code of Virginia. A law-enforcement agency shall not use a system for the purpose of interfering with individuals engaged in lawful activities or tracking individuals on the basis of the content of lawfully protected speech. ALPR systems are used to identify vehicles, not persons.

B. §2.2-5517, section D, Code of Virginia, provides that a law-enforcement agency may use a system only (i) as part of a criminal investigation into an alleged violation of the Code of Virginia or any ordinance of any county, city, or town where there is a reasonable suspicion that a crime was committed; (ii) as part of an active investigation related to a missing or endangered person, including whether to issue an alert for such person, or a person associated with human trafficking; or (iii) to receive notifications related to a missing or endangered person, a person with an outstanding warrant, a person associated with human trafficking, a stolen vehicle, or a stolen license plate. All information necessary for the creation of an audit trail shall be entered in order to query system data. A law-enforcement agency shall not query or download system data unless such data is related to at least one of these purposes. A law-enforcement agency may download audit trail data for purposes of generating audit reports. A stop of a motor vehicle based on a notification from the system shall be consistent with §2.2-5517, section M, Code of Virginia.

C. Notification of an Alert

1. Notification by a system does not constitute reasonable suspicion as grounds for law enforcement to stop a vehicle. Prior to stopping a vehicle based on a notification, a law-enforcement officer shall:
 - a. Develop independent reasonable suspicion for the stop; or
 - b. Confirm the license plate or identifying characteristics of a vehicle match the information contained in the database used to generate the notification.
 - i. This confirmation procedure shall be an independent comparison of the ALPR system alert and the corresponding hot list notification.
 - ii. Law-enforcement officers are encouraged to use radio communication to verify the ALPR system alert.
2. If a law-enforcement officer stops the driver of a motor vehicle, stops and frisks
 - i. a person based on reasonable suspicion, or temporarily detains a person during
 - ii. any other investigatory stop based upon the alarm of an ALPR, the reporting
 - iii. requirements set forth in 52-30.2, section C, Code of Virginia, shall be followed.

D. ALPR Hot Lists

1. The primary use of ALPR data involves the comparison of license plate characters collected by an ALPR system to characters contained on a previously compiled hot list. These hot lists may be compiled by the local, state or federal law enforcement. These hot lists inform law enforcement which vehicles are of interest and why, alerting the user when such a vehicle is read by an ALPR camera. This can be done in real time or using historical ALPR data.
2. Hot lists shall be updated at least once every 24 hours, or as soon as practicable, after such updates become available.

- a. The Virginia State Police distributes the NCIC hot list four times daily
- b. The law-enforcement agency should coordinate directly with the Virginia State Police or through their ALPR vendor the accuracy and currency of the NCIC hot list.
- c. The law-enforcement agency operated hot list or manually entered hot listed license plate(s) shall be updated as soon as practicable.
- d. Manually entered license plate lists shall contain at a minimum:
 - i. Supporting information regarding why a particular license plate is on a specific hot list.
 - ii. Vehicle description (year, make, model, and color)
 - iii. Legal reason for entry
 - iv. Valid 24-hour contact number of entrant or agency
 - v. If available, valid case number or CAD/incident number

E. Training Requirements

1. Employees must attend training prior to using or accessing the ALPR system
2. ALPR training should include the following:
 - a. Legal update of relevant ALPR matters
 - b. Administrative procedures
 - c. Technical procedures

F. System Data Usage - Retention and Sharing

1. System data dissemination, sharing, and disclosure is defined in §2.2-5517, section F, Code of Virginia.
 - a. This section mandates ALPR system data may not be retained beyond 21 days unless:
 - i. The system data or the audit trail data is part of an ongoing investigation, prosecution, or civil action
 - ii. Such data shall be retained by the law-enforcement agency until (i) the investigation concludes without any criminal charges or (ii) the final disposition of any criminal or civil matter related to the data, including any direct appeals and any writs of habeas corpus pursuant to Article 3 (§8.01-654 et seq.) of Chapter 25 of Title 8.01 or federal law, in

accordance with applicable records retention law and policy.

2. ALPR system data may only be downloaded from the system purposes described in §2.2-5517, Code of Virginia.
3. ALPR system data may not be sold by its employees or its contracted ALPR vendor(s).
4. System data and audit trail data is not subject to disclosure under Virginia Freedom of Information Act (FOIA).
5. When releasing ALPR information to another law-enforcement agency, it is important to note that §2.2-5517, section A, Code of Virginia, defines a law enforcement agency as any agency or entity that employs law-enforcement officers as defined in §9.1-101, Code of Virginia.

G. Administrative Process

1. Internal system auditing shall occur at least once every 30 days.
 - a. Internal system audits shall be conducted in the following use areas:
 - i. . Queries Conducted – At least 5% of the total monthly queries conducted should be audited to ensure compliance with of §2.2-5517, section D, Code of Virginia (Reference Virginia Code 2.2-5517 Section I. 3).
 - ii. Downloads – At least 5% of the total monthly downloads should be audited to ensure compliance with §2.2-5517, Code of Virginia.
 - iii. Traffic Stops – At least 5% of the total monthly traffic stops conducted as the result of an LPR alarm should be audited to ensure compliance.
 - iv. Agency Sharing – A monthly system audit shall verify system settings to ensure compliance with §2.2-5517, section F (1), Code of Virginia.
2. ALPR data and audit trail data shall be purged and rendered not recoverable in accordance with §2.2-5517, section E, Code of Virginia.
3. ALPR data and audit trail data shall be purged and rendered not recoverable in accordance with §2.2-5517, section E, Code of Virginia.

D. Data Security and Access

- a. ALPR data is categorized as “for official use only.” Ensuring ALPR data remains secure builds public confidence in this technology. Access control to the administrative profile(s) of the ALPR system shall be maintained.
- b. All collected data will be maintained on a server that is not connected to, or shared with, other law-enforcement databases.

E. ALPR Program Manager

- a. The law-enforcement agency should designate an individual who possesses decision making authority to manage the ALPR program.
- b. The individual should, at a minimum:
 - i. Stay abreast of current case law and legislation
 - ii. Monitor the use of the ALPR system and conduct periodic audits
 - iii. Manage user accounts and permissions
 - iv. Manage ALPR training
 - v. Updates ALPR policy as necessary

Code of Virginia
Title 2.2. Administration of Government
Subtitle II. Administration of State Government
Part B. Transaction of Public Business
Chapter 55.6. Use of Automatic License Plate Recognition Systems

**§ 2.2-5517. Use of automatic license plate recognition systems
by law-enforcement agencies**

A. For purposes of this section:

"Audit trail" means all records of queries and responses in an automatic license plate recognition system, and all records of actions in which system data is accessed, entered, updated, shared, or disseminated, including the (i) date and time of access; (ii) license plate number or other data elements used to query the system; (iii) specific purpose, as set forth in subsection D, for accessing or querying the system, including the offense type for any criminal investigation; (iv) associated call for service or case number; and (v) username of the person or persons who accessed or queried the system.

"Audit trail data" means all forms of data collected or generated by an automatic license plate recognition system for purposes of producing an audit trail.

"Automatic license plate recognition system" or "system" means a system of one or more highspeed cameras used in combination with computer algorithms to convert images of license plates, vehicles, or a combination of both into computer-readable data.

"Division" means the Division of Purchases and Supply of the Department of General Services.

"Law-enforcement agency" means any agency or entity that employs law-enforcement officers as defined in § 9.1-101.

"Missing or endangered person" means a person who has been identified as missing or endangered based on information provided by the National Criminal Information Center, the National Center for Missing and Exploited Children, or the Missing Children Information Clearinghouse (§ 52-31 et seq.) or pursuant to a Virginia Amber Alert (§ 52-34.1 et seq.), a Virginia Critical Operation for a Disappeared Child Initiative Alert (§ 52-34.3:1 et seq.), a Virginia Senior Alert (§ 52-34.4 et seq.), a Virginia Blue Alert (§ 52-34.7 et seq.), a Virginia Critically Missing Adult Alert (§ 52-34.10 et seq.), a Virginia Missing Person with Autism Alert (§ 52-34.13 et seq.), or any substantially similar alert under the laws of another state or territory of the United States, the District of Columbia, or the United States.

"Notification" means an alert from an automatic license plate recognition system that a license plate or vehicle matches a license plate or vehicle in a database utilized by the automatic license plate recognition system for comparison purposes.

"Person associated with human trafficking" means a person who is either a suspected victim or an alleged perpetrator of either commercial sex trafficking or labor trafficking.

"Publicly post" means to post on a website that is maintained by the agency or on any other website on which the agency generally posts information and that is available to the public or that clearly describes how the public may access such information.

"Query" means a search of automatic license plate recognition system data based on information entered by the user, including a full or partial license plate number, any identifying characteristics of a vehicle, the date, time, or location of an image, or any other data that is searchable within the automatic license plate recognition system.

"System data" means all forms of data collected or generated by an automatic license plate recognition system, including images of license plates, vehicles, any identifying characteristics of vehicles, the date, time, and location of an image, and any peripheral images collected from which analytical data may be extracted.

"Vendor" means a business, company, corporation, or other nongovernmental entity that contracts with a law-enforcement agency for the installation, use, or maintenance of an automatic license plate recognition system.

B. Pursuant to § 2.2-1112, the Division of Purchases and Supply shall determine the automatic license plate recognition systems for use in the Commonwealth in accordance with this section. An automatic license plate recognition system shall not be approved by the Division for use by a law-enforcement agency unless:

1. The vendor certifies that it will not sell or share any system data or audit trail data gathered in the Commonwealth, except upon request of the contracting law-enforcement agency for a purpose set forth in subsection F, and will only access system data or audit trail data upon request of the contracting law-enforcement agency for maintenance and quality assurance purposes;
2. The vendor certifies that its system is capable of purging system data collected or generated in the Commonwealth after 21 days of the date of its capture, or earlier if requested by the contracting law-enforcement agency, in such a manner that the system data is destroyed and not recoverable by either the vendor or the contracting law-enforcement agency;
3. The vendor certifies that its system is capable of producing an audit trail and purging audit trail data collected or generated in the Commonwealth after two years of the date of its capture in such a manner that the audit trail data is destroyed and not recoverable by either the vendor or the contracting law-enforcement agency;
4. The databases used by the system to provide notifications as set forth in subsection D are updated at least every 24 hours, or as soon as practicable after such updates become available; and
5. The system meets information security standards as established by the Virginia Information Technologies Agency.

C. (Effective July 1, 2026) A law-enforcement agency may enter into a contract with a vendor for the installation, use, or maintenance of a system approved by the Division. The contract shall specify that system data and audit trail data will be the property of the law-enforcement agency and that the system meets the requirements set forth in subsection B. The contract shall further specify that the vendor will immediately notify the law-enforcement agency upon receipt of any subpoena duces tecum, execution of any search warrant, or any other request from a third party

for such system data or audit trail data, unless disclosure of such subpoena duces tecum, search warrant, or request is otherwise prohibited by law.

2 4/15/2026 12:00:00

D. A law-enforcement agency may use a system only (i) as part of a criminal investigation into an alleged violation of the Code of Virginia or any ordinance of any county, city, or town where there is a reasonable suspicion that a crime was committed; (ii) as part of an active investigation related to a missing or endangered person, including whether to issue an alert for such person, or a person associated with human trafficking; or (iii) to receive notifications related to a missing or endangered person, a person with an outstanding warrant, a person associated with human trafficking, a stolen vehicle, or a stolen license plate. All information necessary for the creation of an audit trail shall be entered in order to query system data. A law-enforcement agency shall not query or download system data unless such data is related to at least one of these purposes. A law-enforcement agency may download audit trail data for purposes of generating audit reports. A stop of a motor vehicle based on a notification from the system shall be consistent with subsection M.

E. System data shall be purged after 21 days of the date of its capture in such a manner that such data is destroyed and not recoverable by either the vendor or the law-enforcement agency. Audit trail data shall be purged after two years of the date of its capture in such a manner that such data is destroyed and not recoverable by either the vendor or the law-enforcement agency. However, if the system data or the audit trail data is part of an ongoing investigation, prosecution, or civil action, such data shall be retained by the law-enforcement agency until (i) the investigation concludes without any criminal charges or (ii) the final disposition of any criminal or civil matter related to the data, including any direct appeals and any writs of habeas corpus pursuant to Article 3 (§ 8.01-654 et seq.) of Chapter 25 of Title 8.01 or federal law, in accordance with applicable records retention law and policy.

F. System data and audit trail data shall not be subject to disclosure under the Virginia Freedom of Information Act (§ 2.2-3700 et seq.). A law-enforcement agency shall not sell any system data or audit trail data. A law-enforcement agency shall not share system data or audit trail data with, or disseminate such data to, any database of any other state, federal, private, or commercial entity. A law-enforcement agency may share system data or audit trail data for the following purposes:

1. With another law-enforcement agency for purposes set forth in subsection D, which may include allowing another law-enforcement agency to query system data, provided that the agency receiving such data shall comply with all of the provisions of this section;
2. With the attorney for the Commonwealth for purposes set forth in subsection D or for complying with discovery or a court order in a criminal proceeding;
3. With a defendant or his counsel for purposes of complying with discovery or a court order in a criminal proceeding;
4. Pursuant to a court order or a court-issued subpoena duces tecum in any criminal or civil proceeding;
5. With the vendor for maintenance or quality assurance purposes; or
6. To alert the public to an emergency situation, a missing or endangered person, a person associated with human trafficking, or a person with an outstanding warrant.

In addition, the Department of State Police shall share system data obtained from any system installed, maintained, and operated on any limited access highway or any bridge, tunnel, or

3 4/15/2026 12:00:00

special structure under the jurisdiction of the Commonwealth Transportation Board or the Department of Transportation with any law-enforcement agency in the locality where such system is installed, maintained, or operated, and such law-enforcement agency may share such system data for the purposes set forth in this subsection.

G. A law-enforcement agency that uses a system shall maintain records sufficient to facilitate public reporting as required by this section, the production of an audit trail, and discovery in criminal and civil proceedings, appeals, and post-conviction proceedings.

H. A law-enforcement agency that uses a system shall establish a policy governing such use that is consistent with this section that includes:

1. Training requirements for individuals who will use or access the system;
2. The purposes for which the system can be used or accessed;
3. Procedures to ensure that the databases used by the system to provide notifications as set forth in subsection D are updated at least every 24 hours, or as soon as practicable after such updates become available;
4. Procedures to confirm the accuracy of any notifications made by the system before stopping a vehicle that are consistent with subsection M;
5. A prohibition against downloading system data that is not related to at least one of the purposes set forth in subsection D, except for downloads of audit trail data for purposes of generating audit reports;
6. An internal auditing procedure that occurs at least once every 30 days;
7. Procedures for the retention and destruction of system data and audit trail data that are consistent with subsection E;
8. A prohibition on the sale of system data and audit trail data and restrictions on the sharing of system data and audit trail data that are consistent with subsection F; and
9. Security procedures to protect the system, system data, and audit trail data from unauthorized access, destruction, use, modification, or disclosure.

I. A law-enforcement agency that uses a system shall report to the Department of State Police by April 1 of each year, in a format to be determined by the Department of State Police, on its use of the system during the preceding calendar year, which shall include the following data:

1. The total number of cameras owned or leased by an agency as part of a system at the conclusion of each calendar year, including the number of such cameras designed to be affixed inside or on a motor vehicle, permanently affixed adjacent to a highway, or temporarily affixed or placed adjacent to a highway for purposes of capturing system data;
2. A list of all state and federal databases with which the system data was compared, unless the existence of any such database itself is not public;
3. The total number of times the system was queried, including the specific purposes of the queries, as set forth in subsection D, and the offense types for any criminal investigation;
4. The race, ethnicity, age, and gender of any individual identified as a suspect and charged with

4/15/2026 12:00:00

a criminal offense as a result of a query of the system as part of a criminal investigation;

5. The number of motor vehicles stopped based on notifications from the system, including the specific reasons for the notifications as set forth in subsection D;

6. The race, ethnicity, age, and gender of the driver of any motor vehicle stopped based on a notification from the system;

7. Whether the agency allows any other law-enforcement agencies to access its system data, and if so, which other agencies have been granted such access;

8. The number of identified instances of unauthorized use of or access to the system, including the nature and circumstances of such instances; and

9. The number of subpoena duces tecum, search warrants, and any other requests received from a third party for system data or audit trail data, including the identity of the entity that requested the issuance of such subpoena duces tecum, executed such search warrant, or requested such data, and whether any data was provided to such entity, unless disclosure of such subpoena duces tecum, search warrant, or request is otherwise prohibited by law.

J. The Department of State Police shall aggregate the data provided pursuant to subsection I and report it to the Governor, the General Assembly, and the Virginia State Crime Commission by July 1 of each year.

K. A law-enforcement agency that uses a system shall publicly post the policy set forth in subsection H and the report set forth in subsection I. Data shall not be publicly posted if it contains personal or case identifying information. If any data (i) contains an articulable concern for any person's safety, (ii) is otherwise prohibited from public disclosure by federal or state statute, or (iii) may compromise sensitive criminal justice information if disclosed, such data may be excluded from being publicly posted.

L. A law-enforcement agency shall not use a system for the purpose of interfering with individuals engaged in lawful activities or tracking individuals on the basis of the content of lawfully protected speech.

M. A notification by a system for purposes set forth in subsection D does not, by itself, constitute reasonable suspicion as grounds for law enforcement to stop a vehicle. Prior to stopping a vehicle based on a notification, a law-enforcement officer shall:

1. Develop independent reasonable suspicion for the stop; or

2. Confirm that the license plate or identifying characteristics of a vehicle match the information contained in the database used to generate the notification.

N. Any person who willfully and intentionally queries, accesses, or uses a system for a purpose other than set forth in subsection D, or who willfully and intentionally sells, shares, or disseminates system data or audit trail data in violation of subsection F, is guilty of a Class 1 misdemeanor.

O. Any evidence obtained as the result of a violation of subsection D, F, L, or M is not admissible by the Commonwealth in any criminal or civil proceeding, but such evidence may be admitted by a defendant in a criminal proceeding or a litigant, other than the Commonwealth, in a civil proceeding.

5 4/15/2026 12:00:00

P. This section does not apply to systems used:

1. For the enforcement of traffic laws, which includes parking regulations, speed limits, tolling requirements, high-occupancy vehicle requirements, or on-road emissions monitoring;
2. By the Department of Motor Vehicles at permanent weighing stations and in mobile weighing operations; or
3. By any state or local agency or any private entity for non-criminal justice purposes.

Q. A vendor shall immediately notify the contracting law-enforcement agency under subsection C upon receipt of a subpoena duces tecum, execution of a search warrant, or any other request from a third party for any system data or audit trail data, unless disclosure of such subpoena duces tecum, search warrant, or request is otherwise prohibited by law.

R. Prior to or coincident with the implementation of an automatic license plate recognition system, a local law-enforcement agency shall take measures to promote public awareness on the use of such system.

2025, c. 720.

The chapters of the acts of assembly referenced in the historical citation at the end of this section(s) may not constitute a comprehensive list of such chapters and may exclude chapters whose provisions have expired.

Code of Virginia
Title 2.2. Administration of Government
Chapter 55.6. Use of Automatic License Plate Recognition Systems

§ 2.2-5517. Use of automatic license plate recognition systems by law-enforcement agencies. (2025 updated section)

A. For purposes of this section:

"Audit trail" means all records of queries and responses in an automatic license plate recognition system, and all records of actions in which system data is accessed, entered, updated, shared, or disseminated, including the (i) date and time of access; (ii) license plate number or other data elements used to query the system; (iii) specific purpose, as set forth in subsection D, for accessing or querying the system, including the offense type for any criminal investigation; (iv) associated call for service or case number; and (v) username of the person or persons who accessed or queried the system.

"Audit trail data" means all forms of data collected or generated by an automatic license plate recognition system for purposes of producing an audit trail.

"Automatic license plate recognition system" or "system" means a system of one or more high-speed cameras used in combination with computer algorithms to convert images of license plates, vehicles, or a combination of both into computer-readable data.

"Division" means the Division of Purchases and Supply of the Department of General Services.

"Law-enforcement agency" means any agency or entity that employs law-enforcement officers as defined in § 9.1-101.

"Missing or endangered person" means a person who has been identified as missing or endangered based on information provided by the National Criminal Information Center, the National Center for Missing and Exploited Children, or the Missing Children Information Clearinghouse (§ 52-51 et seq.) or pursuant to a Virginia Amber Alert (§ 52-34.1 et seq.), a Virginia Critical Operation for a Disappeared Child Initiative Alert (§ 52-34.3:1 et seq.), a Virginia Senior Alert (§ 52-34.4 et seq.), a Virginia Blue Alert (§ 52-34.7 et seq.), a Virginia Critically Missing Adult Alert (§ 52-34.10 et seq.), a Virginia Missing Person with Autism Alert (§ 52-34.13 et seq.), or any substantially similar alert under the laws of another state or territory of the United States, the District of Columbia, or the United States.

"Notification" means an alert from an automatic license plate recognition system that a license plate or vehicle matches a license plate or vehicle in a database utilized by the automatic license plate recognition system for comparison purposes.

"Person associated with human trafficking" means a person who is either a suspected victim or an alleged perpetrator of either commercial sex trafficking or labor trafficking.

"Publicly post" means to post on a website that is maintained by the agency or on any other website on which the agency generally posts information and that is available to the public or that clearly describes how the public may access such information.

"Query" means a search of automatic license plate recognition system data based on information entered by the user, including a full or partial license plate number, any identifying characteristics of a vehicle, the date, time, or location of an image, or any other data that is searchable within the automatic license plate recognition system.

"System data" means all forms of data collected or generated by an automatic license plate recognition system, including images of license plates, vehicles, any identifying characteristics of vehicles, the date, time, and location of an image, and any peripheral images collected from which analytical data may be extracted.

"Vendor" means a business, company, corporation, or other nongovernmental entity that contracts with a law-enforcement agency for the installation, use, or maintenance of an automatic license plate recognition system.

B. Pursuant to § 2.2-1112, the Division of Purchases and Supply shall determine the automatic license plate recognition systems for use in the Commonwealth in accordance with this section. An automatic license plate recognition system shall not be approved by the Division for use by a law-enforcement agency unless:

1. The vendor certifies that it will not sell or share any system data or audit trail data gathered in the Commonwealth, except upon request of the contracting law-enforcement agency for a purpose set forth in subsection F, and will only access system data or audit trail data upon request of the contracting law-enforcement agency for maintenance and quality assurance purposes;
2. The vendor certifies that its system is capable of purging system data collected or generated in the Commonwealth after 21 days of the date of its capture, or earlier if requested by the contracting law-enforcement agency, in such a manner that the system data is destroyed and not recoverable by either the vendor or the contracting law-enforcement agency;
3. The vendor certifies that its system is capable of producing an audit trail and purging audit trail data collected or generated in the Commonwealth after two years of the date of its capture in such a manner that the audit trail data is destroyed and not recoverable by either the vendor or the contracting law-enforcement agency;
4. The databases used by the system to provide notifications as set forth in subsection D are updated at least every 24 hours, or as soon as practicable after such updates become available; and
5. The system meets information security standards as established by the Virginia Information Technologies Agency.

C. (Effective July 1, 2026) A law-enforcement agency may enter into a contract with a vendor for the installation, use, or maintenance of a system approved by the Division. The contract shall specify that system data and audit trail data will be the property of the law-enforcement agency and that the system meets the requirements set forth in subsection B. The contract shall further specify that the vendor will immediately notify the law-enforcement agency upon receipt of any subpoena duces tecum, execution of any search warrant, or any other request from a third party for such system data or audit trail data, unless disclosure of such

county, city, or town where there is a reasonable suspicion that a crime was committed; (ii) as part of an active investigation related to a missing or endangered person, including whether to issue an alert for such person, or a person associated with human trafficking; or (iii) to receive notifications related to a missing or endangered person, a person with an outstanding warrant, a person associated with human trafficking, a stolen vehicle, or a stolen license plate. All information necessary for the creation of an audit trail shall be entered in order to query system data. A law-enforcement agency shall not query or download system data unless such data is related to at least one of these purposes. A law-enforcement agency may download audit trail data for purposes of generating audit reports. A stop of a motor vehicle based on a notification from the system shall be consistent with subsection M.

E. System data shall be purged after 21 days of the date of its capture in such a manner that such data is destroyed and not recoverable by either the vendor or the law-enforcement agency. Audit trail data shall be purged after two years of the date of its capture in such a manner that such data is destroyed and not recoverable by either the vendor or the law-enforcement agency. However, if the system data or the audit trail data is part of an ongoing investigation, prosecution, or civil action such data shall be retained by the law-enforcement agency until (i) the investigation concludes without any criminal charges or (ii) the final disposition of any criminal or civil matter related to the data, including any direct appeals and any writs of habeas corpus pursuant to Article 3 (§ 8.01-654 et seq.) of Chapter 25 of Title 8.01 or federal law, in accordance with applicable records retention law and policy.

F. System data and audit trail data shall not be subject to disclosure under the Virginia Freedom of Information Act (§ 2.2-3700 et seq.). A law-enforcement agency shall not sell any system data or audit trail data. A law-enforcement agency shall not share system data or audit trail data with, or disseminate such data to, any database of any other state, federal, private, or commercial entity. A law-enforcement agency may share system data or audit trail data for the following purposes:

1. With another law-enforcement agency for purposes set forth in subsection D, which may include allowing another law-enforcement agency to query system data provided that the agency receiving such data shall comply with all of the provisions of this section;
2. With the attorney for the Commonwealth for purposes set forth in subsection D or for complying with discovery or a court order in a criminal proceeding;
3. With a defendant or his counsel for purposes of complying with discovery or a court order in a criminal proceeding;
4. Pursuant to a court order or a court-issued subpoena duces tecum in any criminal or civil proceeding;
5. With the vendor for maintenance or quality assurance purposes; or
6. To alert the public to an emergency situation, a missing or endangered person, a person associated with human trafficking, or a person with an outstanding warrant.

In addition, the Department of State Police shall share system data obtained from any system installed, maintained, and operated on any limited access highway or any bridge, tunnel, or special structure under the jurisdiction of the Commonwealth Transportation Board or the Department of Transportation with any law-enforcement agency in the locality where such system is installed, maintained, or operated, and such law-enforcement agency may share such system data for the purposes set forth in this subsection.

G. A law-enforcement agency that uses a system shall maintain records sufficient to facilitate public reporting as required by this section, the production of an audit trail, and discovery in criminal and civil proceedings, appeals, and post-conviction proceedings.

H. A law-enforcement agency that uses a system shall establish a policy governing such use that is consistent with this section that includes:

1. Training requirements for individuals who will use or access the system;
2. The purposes for which the system can be used or accessed;
3. Procedures to ensure that the databases used by the system to provide notifications as set forth in subsection D are updated at least every 24 hours, or as soon as practicable after such updates become available;
4. Procedures to confirm the accuracy of any notifications made by the system before stopping a vehicle that are consistent with subsection M;
5. A prohibition against downloading system data that is not related to at least one of the purposes set forth in subsection D, except for downloads of audit trail data for purposes of generating audit reports;
6. An internal auditing procedure that occurs at least once every 30 days;
7. Procedures for the retention and destruction of system data and audit trail data that are consistent with subsection E;
8. A prohibition on the sale of system data and audit trail data and restrictions on the sharing of system data and audit trail data that are consistent with subsection D and
9. Security procedures to protect the system, system data, and audit trail data from unauthorized access, destruction, use, modification, or disclosure.

I. A law-enforcement agency that uses a system shall report to the Department of State Police by April 1 of each year, in a format to be determined by the Department of State Police, on its use of the system during the preceding calendar year, which shall include the following data:

1. The total number of cameras owned or leased by an agency as part of a system at the conclusion of each calendar year, including the number of such cameras designed to be affixed inside or on a motor vehicle, permanently affixed adjacent to a highway, or temporarily affixed or placed adjacent to a highway for purposes capturing system data;
2. A list of all state and federal databases with which the system data was compared, unless the existence of any such database itself is not public;
3. The total number of times the system was queried, including the specific purposes of the queries, as set forth in subsection D, and the offense types for any criminal investigation;
4. The race, ethnicity, age, and gender of any individual identified as a suspect and charged with a criminal offense as a result of a query of the system as part of a criminal investigation;
5. The number of motor vehicles stopped based on notifications from the system, including the specific reasons for the notifications as set forth in subsection D;

7. Whether the agency allows any other law-enforcement agencies to access its system data, and if so, which other agencies have been granted such access;

8. The number of identified instances of unauthorized use of or access to the system, including the nature and circumstances of such instances; and

9. The number of subpoena duces tecum, search warrants, and any other requests received from a third party for system data or audit trail data, including the identity of the entity that requested the issuance of such subpoena duces tecum, executed such search warrant, or requested such data, and whether any data was provided such entity, unless disclosure of such subpoena duces tecum, search warrant, or request is otherwise prohibited by law.

J. The Department of State Police shall aggregate the data provided pursuant to subsection I and report it to the Governor, the General Assembly, and the Virginia State Crime Commission by July 1 of each year.

K. A law-enforcement agency that uses a system shall publicly post the policy set forth in subsection H and the report set forth in subsection I. Data shall not be publicly posted if it contains personal or case identifying information. If any data (i) contains an articulable concern for any person's safety, (ii) is otherwise prohibited from public disclosure by federal or state statute, or (iii) may compromise sensitive criminal justice information if disclosed, such data may be excluded from being publicly posted.

L. A law-enforcement agency shall not use a system for the purpose of interfering with individuals engaged in lawful activities or tracking individuals on the basis of the content of lawfully protected speech.

M. A notification by a system for purposes set forth in subsection D does not, by itself, constitute reasonable suspicion as grounds for law enforcement to stop a vehicle. Prior to stopping a vehicle based on a notification, a law-enforcement officer shall:

1. Develop independent reasonable suspicion for the stop; or
2. Confirm that the license plate or identifying characteristics of a vehicle match the information contained in the database used to generate the notification.

N. Any person who willfully and intentionally queries, accesses, or uses a system for a purpose other than set forth in subsection D, or who willfully and intentionally sells, shares, or disseminates system data or audit trail data in violation of subsection F, is guilty of a Class 1 misdemeanor.

O. Any evidence obtained as the result of a violation of subsection D, F, L, or M is not admissible by the Commonwealth in any criminal or civil proceeding, but such evidence may be admitted by a defendant in a criminal proceeding or a litigant, other than the Commonwealth, in a civil proceeding.

P. This section does not apply to systems used:

1. For the enforcement of traffic laws, which includes parking regulations, speed limits, tolling requirements, high-occupancy vehicle requirements, or on-road emissions monitoring;
2. By the Department of Motor Vehicles at permanent weighing stations and in mobile weighing operations; or
3. By any state or local agency or any private entity for non-criminal justice purposes.

Q. A vendor shall immediately notify the contracting law-enforcement agency under subsection C upon receipt of a subpoena duces tecum, execution of a search warrant, or any other request from a third party for any system data or audit trail data, unless disclosure of such subpoena duces tecum, search warrant, or request is otherwise prohibited by law.

R. Prior to or coincident with the implementation of an automatic license plate recognition system, a local law-enforcement agency shall take measures to promote public awareness on the use of such system.

2025, c. 720.

PURPOSE OF REQUEST

Please describe the type of equipment, training, software, or recurring costs you are requesting to purchase; include the reason for your request and how this HEAT funding will be used to support your agency's efforts in combating the theft of vehicles and vehicle parts in your jurisdiction. Please attach extra pages as necessary.

On behalf of the Elkton Police Department, Elkton VA, I am submitting this grant application for \$12,500.00 for the HEAT grant funding. Our department intends to utilize the money obtained from this grant to purchase several FLOCK traffic cameras and software. This resource will be instrumental in locating stolen vehicles coming through the Town of Elkton and the eastern region of Rockingham County and southern Page County. As of right now, there is no equipment/technology on the eastern side of the county or our town. The City of Harrisonburg has this technology but it does not serve our town or the citizens on this side of the county. Our town is unique in the fact that we have two major highways that pass through our town, "Spotswood Trail" Route 33 and "East Side Highway" Route 340. With these highways passing through within town limits, they bring several thousands of vehicles through this area; whether they are traveling east bound on Spotswood Trail to Greene County and Charlottesville or west bound to Harrisonburg. East Side Highway is also a major artery into Page County to US Highway 66 or south to the City of Waynesboro, through Augusta County.

Given these major roadways through the town, we are in a good position to locate and intercept criminal activity involving motor vehicles. With this funding we intend on purchasing three to four of the FLOCK cameras and placing them on the main roadways within the town limits of Elkton. By purchasing this equipment we will be able to work more efficiently with surrounding jurisdictions by providing them with vehicle information and direction of travel.

SUBMITTING YOUR APPLICATION

Please submit completed applications and/or questions to:

First Sergeant Peter W. Lazear

HEAT Program Coordinator
peter.lazear@vsp.virginia.gov
Cell Phone: (804) 221-0997

Applications will be processed on a first-come basis beginning July 1, 2024.

Once your application has been reviewed, you will receive an email informing you if your purchase is approved. If your application is approved then you may initiate your purchase(s). Once payment is made in full, please email receipts or other proof of payment to F/Sgt Lazear. Reimbursement will then be authorized to your agency via your FIN.

Please note that all receipts must be received no later than May 31, 2025.

VIRGINIA STATE POLICE



HELP ELIMINATE AUTO THEFT

FISCAL YEAR 2026 EQUIPMENT REIMBURSEMENT APPLICATION

REQUESTING AGENCY INFORMATION

DATE OF REQUEST: 07/01/2025

AGENCY NAME: ELKTON POLICE DEPARTMENT

AGENCY ADDRESS: 173 W. SPOTSWOOD AVE
Street Address

ELKTON VA 22827
City State Zip Code

AGENCY FEDERAL TAX IDENTIFICATION NUMBER (FIN): _____

REIMBURSEMENT AMOUNT REQUESTED: \$ 10,000.00 (Maximum Reimbursement: \$10,000.00)

REQUESTING AGENCY REPRESENTATIVE CONTACT INFORMATION

TITLE AND NAME: SERGEANT RYAN M. INSANA

E-MAIL: rinsana@townofelkton.com PHONE: 5404352053

[REDACTED]

PURPOSE OF REQUEST

Please use the space below to describe in detail the type of equipment, training, software, or recurring equipment costs you are requesting to purchase; include the reason for your request and how this HEAT funding will be used to support your agency's efforts in combating the theft of vehicles and/or vehicle parts in your jurisdiction. Please attach extra pages as necessary.

This request will provide the funds to continue to pay for our Flock camera system and software that we are using within the Town of Elkton. This system has been instrumental to our department and surrounding localities in helping with criminal investigations, stolen vehicle investigations, stolen license plates, and hit and run investigations. Our current subscription for our camera system is \$12,300.00, so the \$10,000.00 grant will help offset the taxpayers burden in using this system to help solve a wide variety of crimes that happen in and around the jurisdiction of the Town of Elkton. Our department is aware of the new laws that have just been put in place by the General Assembly and have made the adequate steps to comply with all state laws and regulation that were enacted to be able to continue to utilize this equipment and software and not violate any citizens rights.

SUBMITTING YOUR APPLICATION

Please submit completed applications and/or questions to:

First Sergeant Peter W. Lazear

HEAT Program Statewide Coordinator

peter.lazear@vsp.virginia.gov

Cell Phone: (804) 221-0997

Applications will be processed on a first-come basis beginning July 1, 2025.

Once your application has been reviewed, you will receive an email informing you if your purchase is approved. If your application is approved then you may initiate your purchase(s). Once payment is made in full, please email receipts or other proof of payment to F/Sgt Lazear. Reimbursement will then be authorized to your agency in accordance with your FIN.

Please note that all receipts must be received no later than May 31, 2026.

flock safety

INVOICE

Flock Group Inc dba Flock Safety
www.flocksafety.com

Invoice Number: INV-81726
Invoice Date: 12/15/2025
Due Date: 1/14/2026
Payment Terms: Net 30
PO#:

Payment Remittance Information

Pay by Check:

Payable to: Flock Group Inc
Memo: INV-81726
Mail to: PO Box 121923
Dallas, TX 75312-1923

If paying by check, please include the remittance slip below.

Pay by ACH:

Account Legal Name: Flock Group Inc.
Account Number: 3302113966
Account Type: Checking
Routing / SWIFT Code: 121140399 / SVBKUS6S

If paying by ACH, please include your invoice number in the memo section of the ACH transfer request.

Please be aware that failure to pay the invoice by the due date may result in an interest penalty or disconnection of service, as specified in your contract.

.....
Detach and Return with Payment

Make Checks Payable to: Flock Group Inc

If sending via Flock Group Inc
USPS: PO Box 121923
Dallas, TX 75312-1923

Or

If sending via Flock Group Inc
UPS, FedEx or 891923
USPS: 885 East Collins Boulevard,
Suite 110
Richardson, TX 75081

Account: VA - Elkton PD

Invoice #: INV-81726

Amount Due: **\$9,487.67**

Amount Enclosed: \$ _____

Flock Safety + VA - Elkton PD

Flock Group Inc.
1170 Howell Mill Rd, Suite 210
Atlanta, GA 30318

MAIN CONTACT:
Brandon Williams
brandon.williams@flocksafety.com
+16784677782

flock safety



**EXHIBIT A
ORDER FORM**

Customer: VA - Elkton PD
 Legal Entity Name: VA - Elkton PD
 Accounts Payable Email: mking@townofelkton.com
 Address: 173 West Spotswood Avenue Elkton, Virginia
 22827

Initial Term: 24 Months
 Renewal Term: 24 Months
 Payment Terms: Net 30
 Billing Frequency: Annual Plan - First Year Invoiced at Signing.
 Retention Period: 30 Days

Hardware and Software Products

Annual recurring amounts over subscription term

Item	Cost	Quantity	Total
*Flock Safety Platform			
Flock Safety Flock OS			\$11,000.00
FlockOS™ - Essentials	Included	1	Included
Flock Safety LPR Products			
Flock Safety Falcon® -	Included	1	Included
Flock Safety Falcon® LR -	Included	1	Included
Flock Safety Video Products			
Flock Safety Condor™ PTZ w/ LTE Service -	Included	1	Included

Professional Services and One Time Purchases

Item	Cost	Quantity	Total
One Time Fees			
Flock Safety Professional Services			
Professional Services - Existing Infrastructure Implementation Fee -	\$150.00	1	\$150.00
Professional Services - Existing Infrastructure Implementation Fee -	\$150.00	1	\$150.00
Professional Services - Advanced Implementation Fee (Falcon LR) -	\$1,000.00	1	\$1,000.00

Subtotal Year 1:	\$12,300.00
Annual Recurring Subtotal:	\$11,000.00
Estimated Tax:	\$0.00
Contract Total:	\$23,300.00

The Term for Flock Hardware shall commence upon first installation and validation, except that the Term for any Flock Hardware that requires self-installation shall commence upon execution of the Agreement. In the event a Customer purchases more than one type of Flock Hardware, the earliest Term start date shall control. In the event a Customer purchases software only, the Term shall commence upon execution of the Agreement.

Billing Schedule

Billing Schedule	Amount (USD)
Year 1	
At Contract Signing	\$12,300.00
Annual Recurring after Year 1	\$11,000.00
Contract Total	\$23,300.00

*Tax not included

Product and Services Description

Flock Safety Platform Items	Product Description
FlockOS™ - Essentials	An integrated public safety platform that detects, centralizes and decodes actionable evidence to increase safety, improve efficiency, and connect the community.
Flock Safety Condor™ PTZ w/ LTE Service -	Law enforcement grade live streamed PTZ camera with 30 days of edge storage. VMS included and server free. Installed and maintained by Flock Safety, turn key-no additional software or integrations required. *Flock provided sim card camera is limited to 25 hours per month of live streaming.
Professional Services - Existing Infrastructure Implementation Fee -	One-time Professional Services engagement. Includes site and safety assessment of existing vertical infrastructure location, camera setup and testing, and shipping and handling in accordance with the Flock Safety Standard Implementation Service Brief.
Flock Safety Falcon® -	Law enforcement grade infrastructure-free (solar power + LTE) license plate recognition camera with Vehicle Fingerprint™ technology (proprietary machine learning software) and real-time alerts for unlimited users.
Flock Safety Falcon® LR -	Law enforcement grade, long range and high vehicle speed license plate recognition camera with Vehicle Fingerprint™ technology (proprietary machine learning software) and real-time alerts for unlimited users, with LTE. AC Power Only.
Professional Services - Existing Infrastructure Implementation Fee -	One-time Professional Services engagement. Includes site and safety assessment of existing vertical infrastructure location, camera setup and testing, and shipping and handling in accordance with the Flock Safety Standard Implementation Service Brief.
Professional Services - Advanced Implementation Fee (Falcon LR) -	One-time Professional Services engagement. Includes site & safety assessment, camera setup & testing, and shipping & handling in accordance with the Flock Safety Advanced Implementation Service Brief.

FlockOS Features & Description

FlockOS Features	Description
Community Network Access	The ability to request direct access to feeds from privately owned Flock Safety Falcon® LPR cameras located in neighborhoods, schools, and businesses in your community, significantly increasing actionable evidence that clears cases.
Unlimited Users	Unlimited users for FlockOS
State Network (License Plate Lookup Only)	Allows agencies to look up license plates on all cameras opted into the Flock Safety network within your state.
Nationwide Network (License Plate Lookup Only)	With the vast Flock Safety sharing network, law enforcement agencies no longer have to rely on just their devices alone. Agencies can leverage a nationwide system boasting 10 billion additional plate reads per month to amplify the potential to collect vital evidence in otherwise dead-end investigations.
Law Enforcement Network Access	The ability to request direct access to evidence detection devices from Law Enforcement agencies outside of your jurisdiction.
Time & Location Based Search	Search full, partial, and temporary plates by time at particular device locations
License Plate Lookup	Look up specific license plate location history captured on Flock devices
Vehicle Fingerprint Search	Search footage using Vehicle Fingerprint™ technology. Access vehicle type, make, color, license plate state, missing / covered plates, and other unique features like bumper stickers, decals, and roof racks.
Insights & Analytics	Reporting tool to help administrators manage their LPR program with device performance data, user and network audits, plate read reports, hot list alert reports, event logs, and outcome reports.
ESRI Based Map Interface	Map-based interface that consolidates all data streams and the locations of each connected asset, enabling greater situational awareness and a common operating picture.
Real-Time NCIC Alerts on Flock ALPR Cameras	Receive automated alerts when vehicles entered into established databases for missing and wanted persons are detected, including the FBI's National Crime Information Center (NCIC) and National Center for Missing & Exploited Children (NCMEC) databases.
Unlimited Custom Hot Lists	Ability to add a suspect's license plate to a custom list and get alerted when it passes by a Flock camera

Taxes shown above are provided as an estimate. Actual taxes are the responsibility of the Customer. This Agreement will automatically renew for successive renewal terms of the greater of one year or the length set forth on the Order Form (each, a "Renewal Term") unless either Party gives the other Party notice of non-renewal at least thirty (30) days prior to the end of the then-current term.

By executing this Order Form, Customer represents and warrants that it has read and agrees all of the terms and conditions contained in the Terms of Service located at <https://www.flocksafety.com/terms-and-conditions>

The Parties have executed this Agreement as of the dates set forth below.

FLOCK GROUP, INC.

Customer: VA - Elkton PD

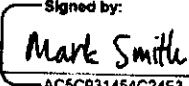
By: 
Name: Mark Smith
Title: General Counsel
Date: 11/12/2024

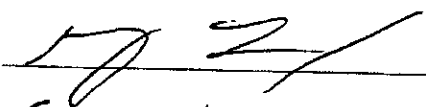
By: 
Name: GREG LUNSFORD
Title: TOWN MANAGER
Date: 11-12-2024
PO Number: NA

AGENCY CUSTOMER ID: CN134017657

LOC #: San Francisco



ADDITIONAL REMARKS SCHEDULE

Page 2 of 2

AGENCY MARSH RISK & INSURANCE SERVICES		NAMED INSURED Flock Group Inc DBA Flock Safety 1170 Howell Mill Rd NW Atlanta, GA 30318	
POLICY NUMBER		EFFECTIVE DATE:	
CARRIER	NAIC CODE		

ADDITIONAL REMARKS

THIS ADDITIONAL REMARKS FORM IS A SCHEDULE TO ACORD FORM,
FORM NUMBER: 25 FORM TITLE: Certificate of Liability Insurance

Carrier will provide notice of cancellation or nonrenewal per below if required by a written contract .

Cancellation For Other Than Nonpayment: Number of Days Notice: 30 days

Cancellation For Nonpayment: Number of Days Notice: 10 days

(Nonrenewal): Number of Days Notice: 10 days



INVOICE

Flock Group Inc dba Flock Safety
www.flocksafety.com

Invoice Number INV-52099
Invoice Date: 11/13/2024
Due Date: 12/13/2024
Payment Terms: Net 30
PO#:

.....
Detach and Return with Payment

Make Checks Payable to: Flock Group Inc

If sending via Flock Group Inc
USPS: PO Box 121923
Dallas, TX 75312-1923

Account: VA - Elkton PD

Or

If sending via Flock Group Inc
UPS, FedEx or 891923
USPS: 1501 North Plano Rd. ste 100
Richardson, TX 75081

Invoice # INV-52099

Amount Due: **\$12,300.00**

Amount Enclosed: \$ _____

Flock Safety + VA - Elkton PD

Flock Group Inc.
1170 Howell Mill Rd, Suite 210
Atlanta, GA 30318

MAIN CONTACT:
Brandon Williams
brandon.williams@flocksafety.com
+16784677782

flock safety

flock safety

AC Powered Installation of Cameras

Flock Safety is a leading provider of License Plate Reading cameras for community-wide safety. The camera system is designed to be infrastructure-free, using cellular networking and solar power, however, there are certain deployments that have limited access to sunlight that require AC power. Flock offers an easy-to-use power kit that enables our customers to work with local electricians to route power to the cameras after the camera is installed, resulting in an efficient quote and installation process.

In this document you will find:

1. AC Powered Installation Process
2. Electrician Installation Steps
3. Frequently Asked Questions

If you have any questions, please call the Flock Safety Installation Support team at 404.793.5197.

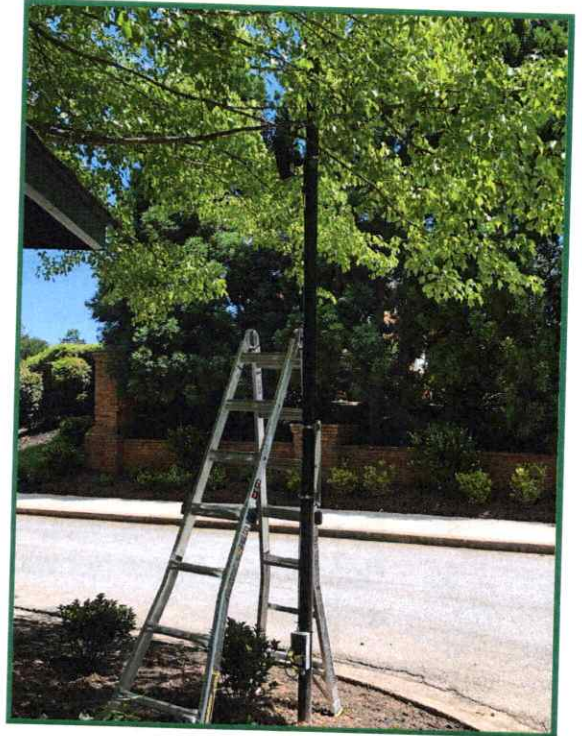

AC Powered Installation Process

1. **Create Deployment Plan with Flock:** Your Flock rep will work with you to select the best location(s) for your LPR cameras. For locations that may require AC power, it will be helpful for you to know where the closest AC power is available so that we can select the closest workable location.
2. **Get Quote from Electrician:** Provide your electrician with this document and the deployment plan and ask them to quote running 120volt AC power to the intended camera location and connect power to the camera as described in the instructions in this document. Explain that we will install the camera and junction box first, and their work can be completed second.

3. **Sign Flock Safety Agreement** : Now that you know the cost of the electrician you will need to sign the Flock Safety purchase order to begin the installation of the cameras
4. **Flock Performs Site Survey**: Flock will mark each camera location and have underground utilities located and marked if present.
5. **Flock Technician Installs Camera**: Flock will install the camera and AC power kit at the specified location and aim the camera. The camera will go to sleep to conserve battery and will turn on when power is present. Flock will send you an email notification once the camera has been successfully installed, letting you know that the site is ready for the final step.
6. **Electrician Connects Power**: The electrician you contract runs power and makes connections inside the Flock-installed junction box at the bottom of the camera pole.

Electrician Installation Steps

1. Run AC cable and conduit to the box according to NEC Article 300 and any applicable local codes. The gland accepts ½" conduit
2. Open the box using hinges
3. Connect AC Mains per wiring diagram below:
 - a. Connect AC Neutral wire to the Surge Protector white Neutral wire (W7) and LED black wire (W11) using the open position on the lever nut.
 - b. Connect AC Line wire to the Surge Protector black Line wire (W9) and LED white (or red) wire (W10) using the open position on the lever nut.
 - c. Connect AC Ground wire to the Surge Protector green ground wire (W8) using the open position on the lever nut.
4. Verify that both the RED and GREEN LED are lit on the front of the box
5. Take a picture to text to Flock to verify correct wiring. 470-279-5592
6. Close box and zip tie the box shut with the provided zip tie
7. While still on site, call Flock who will remotely verify that power is working correctly: 404-793-5197



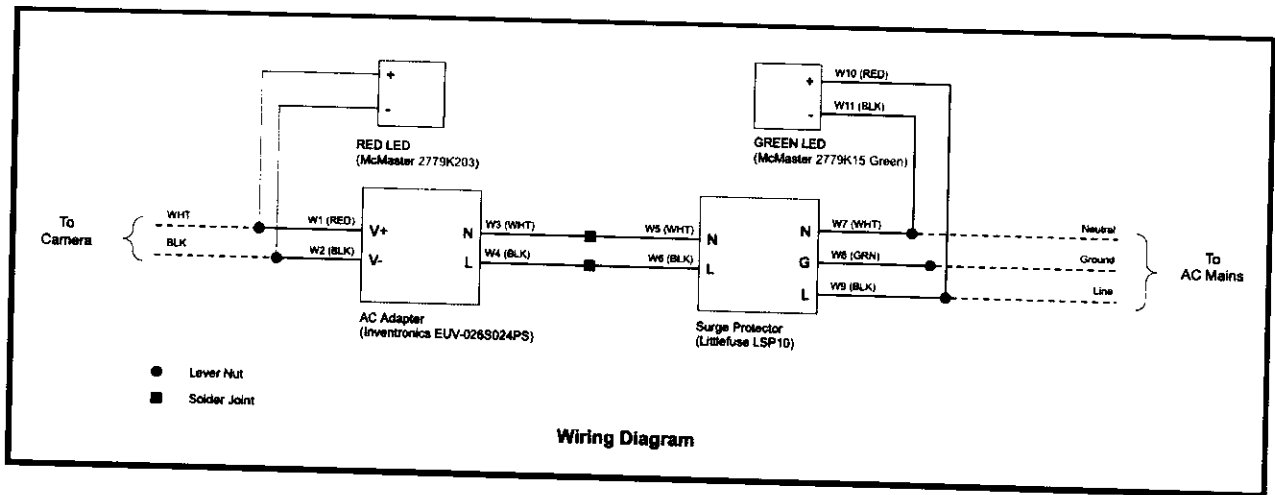

Frequently Asked Questions

- **Who is responsible for contracting the electrician:** The customer is responsible for contracting an electrician. We can help answer questions, but the customer is responsible for identifying and contracting an electrician.
- **Who is responsible for maintenance?** Flock will handle all maintenance related to the camera and power equipment installed by Flock. However, any problems with the electrical supply are the responsibility of the customer. The AC junction box has two lights to indicate presence of power and make it easy for quick diagnosis if there is a problem related to AC power source.
 - In the event the camera indicates to Flock that there is a power supply problem, Flock will notify the customer and request that the customer verify the lights on the AC junction box. If the AC Source light is illuminated, Flock will send a technician to investigate. If the AC source light is not illuminated the customer should check any GFCI's or breakers in the supply circuit or call the electrician who installed the power supply.
- **How much does it cost?** Work required to bring AC power to each location will be different, so exact pricing is not possible. The primary driver of cost is the distance from AC power source to the intended camera location.
- **What information do I need to provide my electrician?** The flock deployment plan and these work instructions should be sufficient to secure a quote. It will be helpful if you know the location of existing power infrastructure before creating the deployment plan.
- **Can you plug into my existing power outlet?** The Flock AC power adapter does not use a standard outlet plug, but must be directly wired into the power mains. While using outlet plugs may be convenient, they can easily be unplugged presenting a tampering risk to this critical safety infrastructure. If an outlet is close to the camera, the electrician can route power directly to the camera with a direct wire-in connection.

- **How long does this process typically take?** The installation process typically takes 2-4 weeks. In order to accelerate the process, be sure to have the electrician perform his work shortly after the Flock technician finishes installing the camera.
- **What kind of electrician should I look for?** Any licensed electrician should be able to perform this work, though we have found that those who advertise working with landscape lighting are most suited for this work.
- **What happens if the electrician damages the equipment?** The customer is responsible for contracting the electrician. Any liability associated with this work would be assumed by the customer. If any future work is required at this site due to the electrical infrastructure or the work performed by the electrician would be the responsibility of the customer.
- **When should the electrician perform his work?** Once Flock installs the camera, you will receive an email alert letting you know that this has been completed. After this, you will need to schedule the electrician to route power to the pole.
- **What if the AC power is on a timer?** Sometimes the AC power will be on a timer (like used for exterior lighting). Flock requires that the AC power provided to the camera be constant. The source that the electrician uses must not be on a timing circuit.

Master Services Agreement

This Master Services Agreement (this "**Agreement**") is entered into by and between Flock Group, Inc. with a place of business at 1170 Howell Mill Road NW Suite 210, Atlanta, GA 30318 ("**Flock**") and the entity identified in the signature block ("**Customer**") (each a "**Party**," and together, the "**Parties**"). This Agreement is effective on the date of mutual execution ("**Effective Date**"). Parties will sign an Order Form ("**Order Form**") which will describe the Flock Services to be performed and the period for performance, attached hereto as **Exhibit A**.

RECITALS

WHEREAS, Flock offers a software and hardware situational awareness solution through Flock's technology platform that upon detection is capable of capturing audio, video, image, and recording data and provide notifications to Customer ("**Notifications**");

WHEREAS, Customer desires access to the Flock Services (defined below) on existing devices, provided by Customer, or Flock provided Flock Hardware (as defined below) in order to create, view, search and archive Footage and receive Notifications, via the Flock Services;

WHEREAS, Customer shall have access to the Footage in Flock Services. Pursuant to Flock's standard Retention Period (defined below) Flock deletes all Footage on a rolling thirty (30) day basis, except as otherwise stated on the **Order Form**. Customer shall be responsible for extracting, downloading and archiving Footage from the Flock Services on its own storage devices; and

WHEREAS, Flock desires to provide Customer the Flock Services and any access thereto, subject to the terms and conditions of this Agreement, solely for the awareness, prevention, and prosecution of crime, bona fide investigations and evidence gathering for law enforcement purposes. ("**Permitted Purpose**").

1. DEFINITIONS

Certain capitalized terms, not otherwise defined herein, have the meanings set forth or cross-referenced in this Section 1.

- 1.1 "**Agreement**" means the order form (to be provided as Exhibit A, "Order Form"), these terms and conditions, and any document therein incorporated by reference in section 11.4.
- 1.2 "**Anonymized Data**" means Customer Data permanently stripped of identifying details and any potential personally identifiable information, by commercially available standards which irreversibly alters data in such a way that a data subject (i.e., individual person or entity) can no longer be identified directly or indirectly.
- 1.3 "**Authorized End User(s)**" means any individual employees, agents, or contractors of Customer accessing or using the Services, under the rights granted to Customer pursuant to this Agreement.
- 1.4 "**Customer Data**" means the data, media, and content provided by Customer through the Services. For the avoidance of doubt, the Customer Data will include the Footage.
- 1.5 "**Customer Hardware**" means the third-party camera owned or provided by Customer and any other physical elements that interact with the Embedded Software and the Web Interface to provide the Services.
- 1.6 "**Effective Date**" means the date this Agreement is mutually executed (valid and enforceable) by both Parties.
- 1.7 "**Embedded Software**" means the Flock proprietary software and/or firmware integrated with or installed on the Flock Hardware or Customer Hardware.
- 1.8 "**Flock Hardware**" means the Flock device(s), which may include the pole, clamps, solar panel, installation components, and any other physical elements that interact with the Embedded Software and the Web Interface, to provide the Flock Services as specifically set forth in the applicable Order Form.
- 1.9 "**Flock IP**" means the Services, the Embedded Software, and any intellectual property or proprietary information therein or otherwise provided to Customer and/or its Authorized End Users. Flock IP does not include Footage (as defined below).
- 1.10 "**Flock Services**" means the provision of Flock's software and hardware situational awareness solution, via the Web Interface, for automatic license plate detection, alerts, audio detection, searching image records, video and sharing Footage.

1.11 "**Footage**" means still images, video, audio, and other data captured by the Flock Hardware or Customer Hardware in the course of and provided via the Flock Services.

1.12 "**Installation Services**" means the services provided by Flock for installation of Flock Services.

1.13 "**Permitted Purpose**" means for legitimate public safety and/or business purpose, including but not limited to the awareness, prevention, and prosecution of crime; investigations; and prevention of commercial harm, to the extent permitted by law.

1.14 "**Retention Period**" means the time period that the Customer Data is stored within the cloud storage, as specified in the applicable Order Form. Flock deletes all Footage on a rolling thirty (30) day basis, except as otherwise stated on the Order Form. Customer shall be responsible for extracting, downloading and archiving Footage from the Flock Services on its own storage devices.

1.15 "**Term**" means the date, unless otherwise stated in the Order Form, upon which the cameras are validated by both Parties as operational.

1.16 "**Web Interface**" means the website(s) or application(s) through which Customer and its Authorized End Users can access the Services.

2. SERVICES AND SUPPORT

2.1 Provision of Access. Flock hereby grants to Customer a non-exclusive, non-transferable right to access the features and functions of the Flock Services via the Web Interface during the Term, solely for the Authorized End Users. The Footage will be available for Authorized End Users to access and download via the Web Interface for the Retention Period. Authorized End Users will be required to sign up for an account and select a password and username ("*User ID*"). Customer shall be responsible for all acts and omissions of Authorized End Users. Customer shall undertake reasonable efforts to make all Authorized End Users aware of all applicable provisions of this Agreement and shall cause Authorized End Users to comply with such provisions. Flock may use the services of one or more third parties to deliver any part of the Flock Services, (such as using a third party to host the Web Interface for cloud storage or a cell phone provider for wireless cellular coverage).

2.2 Embedded Software License. Flock grants Customer a limited, non-exclusive, non-transferable, non-sublicensable (except to the Authorized End Users), revocable right to use the Embedded Software as it pertains to Flock Services, solely as necessary for Customer to use the Flock Services.

2.3 Support Services. Flock shall monitor the Flock Services, and any applicable device health, in order to improve performance and functionality. Flock will use commercially reasonable efforts to respond to requests for support within seventy-two (72) hours. Flock will provide Customer with reasonable technical and on-site support and maintenance services in-person, via phone or by email at support@flocksafety.com (such services collectively referred to as "*Support Services*").

2.4 Updates to Platform. Flock may make any updates to system or platform that it deems necessary or useful to (i) maintain or enhance the quality or delivery of Flock's products or services to its agencies, the competitive strength of, or market for, Flock's products or services, such platform or system's cost efficiency or performance, or (ii) to comply with applicable law. Parties understand that such updates are necessary from time to time and will not diminish the quality of the services or materially change any terms or conditions within this Agreement.

2.5 Service Interruption. Services may be interrupted in the event that: (a) Flock's provision of the Services to Customer or any Authorized End User is prohibited by applicable law; (b) any third-party services required for Services are interrupted; (c) if Services are being used for

malicious, unlawful, or otherwise unauthorized use; (d) there is a threat or attack on any of the Flock IP by a third party; or (e) scheduled or emergency maintenance ("*Service Interruption*"). Flock will make commercially reasonable efforts to provide written notice of any Service Interruption to Customer, to provide updates, and to resume providing access to Flock Services as soon as reasonably possible after the event giving rise to the Service Interruption is cured. Flock will have no liability for any damage, liabilities, losses (including any loss of data or profits), or any other consequences that Customer or any Authorized End User may incur as a result of a Service Interruption. To the extent that the Service Interruption is not caused by Customer's direct actions or by the actions of parties associated with the Customer, the time will be tolled by the duration of the Service Interruption (for any continuous suspension lasting at least one full day). For example, in the event of a Service Interruption lasting five (5) continuous days, Customer will receive a credit for five (5) free days at the end of the Term.

2.6 Service Suspension. Flock may temporarily suspend Customer's and any Authorized End User's access to any portion or all of the Flock IP or Flock Service if (a) there is a threat or attack on any of the Flock IP by Customer; (b) Customer's or any Authorized End User's use of the Flock IP disrupts or poses a security risk to the Flock IP or any other customer or vendor of Flock; (c) Customer or any Authorized End User is are using the Flock IP for fraudulent or illegal activities; (d) Customer has violated any term of this provision, including, but not limited to, utilizing Flock Services for anything other than the Permitted Purpose; or (e) any unauthorized access to Flock Services through Customer's account ("*Service Suspension*"). Customer shall not be entitled to any remedy for the Service Suspension period, including any reimbursement, tolling, or credit. If the Service Suspension was not caused by Customer, the Term will be tolled by the duration of the Service Suspension.

2.7 Hazardous Conditions. Flock Services do not contemplate hazardous materials, or other hazardous conditions, including, without limit, asbestos, lead, or toxic or flammable substances. In the event any such hazardous materials are discovered in the designated locations in which Flock is to perform services under this Agreement, Flock shall have the right to cease work immediately.

3. CUSTOMER OBLIGATIONS

3.1 Customer Obligations. Flock will assist Customer Authorized End Users in the creation of a User ID. Authorized End Users agree to provide Flock with accurate, complete, and updated registration information. Authorized End Users may not select as their User ID, a name that they do not have the right to use, or any other name with the intent of impersonation. Customer and Authorized End Users may not transfer their account to anyone else without prior written permission of Flock. Authorized End Users shall not share their account username or password information and must protect the security of the username and password. Unless otherwise stated and defined in this Agreement, Customer shall not designate Authorized End Users for persons who are not officers, employees, or agents of Customer. Authorized End Users shall only use Customer-issued email addresses for the creation of their User ID. Customer is responsible for any Authorized End User activity associated with its account. Customer shall ensure that Customer provides Flock with up-to-date contact information at all times during the Term of this agreement. Customer shall be responsible for obtaining and maintaining any equipment and ancillary services needed to connect to, access or otherwise use the Flock Services (e.g., laptops, internet connection, mobile devices, etc.). Customer shall (at its own expense) provide Flock with reasonable access and use of Customer facilities and Customer personnel in order to enable Flock to perform Services (such obligations of Customer are collectively defined as "**Customer Obligations**").

3.2 Customer Representations and Warranties. Customer represents, covenants, and warrants that Customer shall use Flock Services only in compliance with this Agreement and all applicable laws and regulations, including but not limited to any laws relating to the recording or sharing of data, video, photo, or audio content.

4. DATA USE AND LICENSING

4.1 Customer Data. As between Flock and Customer, all right, title and interest in the Customer Data, belong to and are retained solely by Customer. Customer hereby grants to Flock a limited, non-exclusive, royalty-free, irrevocable, worldwide license to use the Customer Data and perform all acts as may be necessary for Flock to provide the Flock Services to Customer. Flock does not own and shall not sell Customer Data.

4.2 Customer Generated Data. Flock may provide Customer with the opportunity to post, upload, display, publish, distribute, transmit, broadcast, or otherwise make available, messages, text, illustrations, files, images, graphics, photos, comments, sounds, music, videos, information,

content, ratings, reviews, data, questions, suggestions, or other information or materials produced by Customer ("**Customer Generated Data**"). Customer shall retain whatever legally cognizable right, title, and interest in Customer Generated Data. Customer understands and acknowledges that Flock has no obligation to monitor or enforce Customer's intellectual property rights of Customer Generated Data. Customer grants Flock a non-exclusive, irrevocable, worldwide, royalty-free, license to use the Customer Generated Data for the purpose of providing Flock Services. Flock does not own and shall not sell Customer Generated Data.

4.3 Anonymized Data. Flock shall have the right to collect, analyze, and anonymize Customer Data and Customer Generated Data to the extent such anonymization renders the data non-identifiable to create Anonymized Data to use and perform the Services and related systems and technologies, including the training of machine learning algorithms. Customer hereby grants Flock a non-exclusive, worldwide, perpetual, royalty-free right to use and distribute such Anonymized Data to improve and enhance the Services and for other development, diagnostic and corrective purposes, and other Flock offerings. Parties understand that the aforementioned license is required for continuity of Services. Flock does not own and shall not sell Anonymized Data.

5. CONFIDENTIALITY; DISCLOSURES

5.1 Confidentiality. To the extent required by any applicable public records requests, each Party (the "**Receiving Party**") understands that the other Party (the "**Disclosing Party**") has disclosed or may disclose business, technical or financial information relating to the Disclosing Party's business (hereinafter referred to as "**Proprietary Information**" of the Disclosing Party). Proprietary Information of Flock includes non-public information regarding features, functionality and performance of the Services. Proprietary Information of Customer includes non-public data provided by Customer to Flock or collected by Flock via Flock Services, which includes but is not limited to geolocation information and environmental data collected by sensors. The Receiving Party agrees: (i) to take the same security precautions to protect against disclosure or unauthorized use of such Proprietary Information that the Party takes with its own proprietary information, but in no event less than commercially reasonable precautions, and (ii) not to use (except in performance of the Services or as otherwise permitted herein) or divulge to any third person any such Proprietary Information. The Disclosing Party agrees that the

foregoing shall not apply with respect to any information that the Receiving Party can document (a) is or becomes generally available to the public; or (b) was in its possession or known by it prior to receipt from the Disclosing Party; or (c) was rightfully disclosed to it without restriction by a third party; or (d) was independently developed without use of any Proprietary Information of the Disclosing Party. Nothing in this Agreement will prevent the Receiving Party from disclosing the Proprietary Information pursuant to any judicial or governmental order, provided that the Receiving Party gives the Disclosing Party reasonable prior notice of such disclosure to contest such order. At the termination of this Agreement, all Proprietary Information will be returned to the Disclosing Party, destroyed or erased (if recorded on an erasable storage medium), together with any copies thereof, when no longer needed for the purposes above, or upon request from the Disclosing Party, and in any case upon termination of the Agreement. Notwithstanding any termination, all confidentiality obligations of Proprietary Information that is trade secret shall continue in perpetuity or until such information is no longer trade secret.

5.2 Usage Restrictions on Flock IP. Flock and its licensors retain all right, title and interest in and to the Flock IP and its components, and Customer acknowledges that it neither owns nor acquires any additional rights in and to the foregoing not expressly granted by this Agreement. Customer further acknowledges that Flock retains the right to use the foregoing for any purpose in Flock's sole discretion. Customer and Authorized End Users shall not: (i) copy or duplicate any of the Flock IP; (ii) decompile, disassemble, reverse engineer, or otherwise attempt to obtain or perceive the source code from which any software component of any of the Flock IP is compiled or interpreted, or apply any other process or procedure to derive the source code of any software included in the Flock IP; (iii) attempt to modify, alter, tamper with or repair any of the Flock IP, or attempt to create any derivative product from any of the foregoing; (iv) interfere or attempt to interfere in any manner with the functionality or proper working of any of the Flock IP; (v) remove, obscure, or alter any notice of any intellectual property or proprietary right appearing on or contained within the Flock Services or Flock IP; (vi) use the Flock Services for anything other than the Permitted Purpose; or (vii) assign, sublicense, sell, resell, lease, rent, or otherwise transfer, convey, pledge as security, or otherwise encumber. Customer's rights. There are no implied rights.

5.3 Disclosure of Footage. Subject to and during the Retention Period, Flock may access, use, preserve and/or disclose the Footage to law enforcement authorities, government officials, and/or

third parties, if legally required to do so or if Flock has a good faith belief that such access, use, preservation or disclosure is reasonably necessary to comply with a legal process, enforce this Agreement, or detect, prevent or otherwise address security, privacy, fraud or technical issues, or emergency situations.

6. PAYMENT OF FEES

6.1 Billing and Payment of Fees. Customer shall pay the fees set forth in the applicable Order Form based on the billing structure and payment terms as indicated in the Order Form. To the extent the Order Form is silent, Customer shall pay all invoices net thirty (30) days from the date of receipt. If Customer believes that Flock has billed Customer incorrectly, Customer must contact Flock no later than thirty (30) days after the closing date on the first invoice in which the error or problem appeared to receive an adjustment or credit. Customer acknowledges and agrees that a failure to contact Flock within this period will serve as a waiver of any claim. If any undisputed fee is more than thirty (30) days overdue, Flock may, without limiting its other rights and remedies, suspend delivery of its service until such undisputed invoice is paid in full. Flock shall provide at least thirty (30) days' prior written notice to Customer of the payment delinquency before exercising any suspension right.

6.2 Notice of Changes to Fees. In the event of any changes to fees, Flock shall provide Customer with sixty (60) days' notice (email sufficient) prior to the end of the Initial Term or Renewal Term (as applicable). Any such changes to fees shall only impact subsequent Renewal Terms.

6.3 Taxes. To the extent Customer is not a tax exempt entity, Customer is responsible for all taxes, levies, or duties, excluding only taxes based on Flock's net income, imposed by taxing authorities associated with the order. If Flock has the legal obligation to pay or collect taxes, including amount subsequently assessed by a taxing authority, for which Customer is responsible, the appropriate amount shall be invoice to and paid by Customer unless Customer provides Flock a legally sufficient tax exemption certificate and Flock shall not charge Customer any taxes from which it is exempt. If any deduction or withholding is required by law, Customer shall notify Flock and shall pay Flock any additional amounts necessary to ensure that the net amount that Flock receives, after any deduction and withholding, equals the amount Flock would have received if no deduction or withholding had been required.

7. TERM AND TERMINATION

7.1 **Term.** The initial term of this Agreement shall be for the period of time set forth on the Order Form (the "**Term**"). Unless otherwise indicated on the Order Form, the Term shall commence upon first installation of Flock Hardware, as applicable. Following the Term, unless otherwise indicated on the Order Form, this Agreement will automatically renew for successive renewal terms of the greater of one year or the length set forth on the Order Form (each, a "**Renewal Term**") unless either Party gives the other Party notice of non-renewal at least thirty (30) days prior to the end of the then-current term.

7.2 **Termination.** Upon termination or expiration of this Agreement, Flock will remove any applicable Flock Hardware at a commercially reasonable time period. In the event of any material breach of this Agreement, the non-breaching Party may terminate this Agreement prior to the end of the Term by giving thirty (30) days prior written notice to the breaching Party; provided, however, that this Agreement will not terminate if the breaching Party has cured the breach prior to the expiration of such thirty (30) day period ("**Cure Period**"). Either Party may terminate this Agreement (i) upon the institution by or against the other Party of insolvency, receivership or bankruptcy proceedings, (ii) upon the other Party's making an assignment for the benefit of creditors, or (iii) upon the other Party's dissolution or ceasing to do business. In the event of a material breach by Flock, and Flock is unable to cure within the **Cure Period**, Flock will refund Customer a pro-rata portion of the pre-paid fees for Services not received due to such termination.

7.3 **Survival.** The following Sections will survive termination: 1, 3, 5, 6, 7, 8.3, 8.4, 9, 11.1 and 11.6.

8. REMEDY FOR DEFECT; WARRANTY AND DISCLAIMER

8.1 **Manufacturer Defect.** Upon a malfunction or failure of Flock Hardware or Embedded Software (a “*Defect*”), Customer must notify Flock’s technical support team. In the event of a Defect, Flock shall make a commercially reasonable attempt to repair or replace the defective Flock Hardware at no additional cost to the Customer. Flock reserves the right, in its sole discretion, to repair or replace such Defect, provided that Flock shall conduct inspection or testing within a commercially reasonable time, but no longer than seven (7) business days after Customer gives notice to Flock.

8.2 **Replacements.** In the event that Flock Hardware is lost, stolen, or damaged, Customer may request a replacement of Flock Hardware at a fee according to the reinstall fee schedule (<https://www.flocksafety.com/reinstall-fee-schedule>). In the event that Customer chooses not to replace lost, damaged, or stolen Flock Hardware, Customer understands and agrees that Flock is not liable for any resulting impact to Flock service, nor shall Customer receive a refund for the lost, damaged, or stolen Flock Hardware.

8.3 **Warranty.** Flock shall use reasonable efforts consistent with prevailing industry standards to maintain the Services in a manner which minimizes errors and interruptions in the Services and shall perform the Installation Services in a professional and workmanlike manner. Services may be temporarily unavailable for scheduled maintenance or for unscheduled emergency maintenance, either by Flock or by third-party providers, or because of other causes beyond Flock’s reasonable control, but Flock shall use reasonable efforts to provide advance notice in writing or by e-mail of any scheduled service disruption.

8.4 **Disclaimer.** THE REMEDY DESCRIBED IN SECTION 8.1 ABOVE IS CUSTOMER’S SOLE REMEDY, AND FLOCK’S SOLE LIABILITY, WITH RESPECT TO DEFECTS. FLOCK DOES NOT WARRANT THAT THE SERVICES WILL BE UNINTERRUPTED OR ERROR FREE; NOR DOES IT MAKE ANY WARRANTY AS TO THE RESULTS THAT MAY BE OBTAINED FROM USE OF THE SERVICES. EXCEPT AS EXPRESSLY SET FORTH IN THIS SECTION, THE SERVICES ARE PROVIDED “AS IS” AND FLOCK DISCLAIMS ALL WARRANTIES, EXPRESS OR IMPLIED, INCLUDING, BUT NOT LIMITED TO, IMPLIED WARRANTIES OF MERCHANTABILITY AND FITNESS FOR A

PARTICULAR PURPOSE. THIS DISCLAIMER ONLY APPLIES TO THE EXTENT ALLOWED BY THE GOVERNING LAW OF THE STATE MENTIONED IN SECTION 11.6.

8.5 **Insurance.** Flock will maintain commercial general liability policies as stated in Exhibit B.

8.6 **Force Majeure.** Parties are not responsible or liable for any delays or failures in performance from any cause beyond their control, including, but not limited to acts of God, changes to law or regulations, embargoes, war, terrorist acts, pandemics (including the spread of variants), issues of national security, acts or omissions of third-party technology providers, riots, fires, earthquakes, floods, power blackouts, strikes, supply chain shortages of equipment or supplies, financial institution crisis, weather conditions or acts of hackers, internet service providers or any other third party acts or omissions.

9. LIMITATION OF LIABILITY; INDEMNITY

9.1 **Limitation of Liability.** NOTWITHSTANDING ANYTHING TO THE CONTRARY, FLOCK, ITS OFFICERS, AFFILIATES, REPRESENTATIVES, CONTRACTORS AND EMPLOYEES SHALL NOT BE RESPONSIBLE OR LIABLE WITH RESPECT TO ANY SUBJECT MATTER OF THIS AGREEMENT OR TERMS AND CONDITIONS RELATED THERETO UNDER ANY CONTRACT, NEGLIGENCE, STRICT LIABILITY, PRODUCT LIABILITY, OR OTHER THEORY: (A) FOR LOSS OF REVENUE, BUSINESS OR BUSINESS INTERRUPTION; (B) INCOMPLETE, CORRUPT, OR INACCURATE DATA; (C) COST OF PROCUREMENT OF SUBSTITUTE GOODS, SERVICES OR TECHNOLOGY; (D) FOR ANY INDIRECT, EXEMPLARY, INCIDENTAL, SPECIAL OR CONSEQUENTIAL DAMAGES; (E) FOR ANY MATTER BEYOND FLOCK'S ACTUAL KNOWLEDGE OR REASONABLE CONTROL INCLUDING REPEAT CRIMINAL ACTIVITY OR INABILITY TO CAPTURE FOOTAGE; OR (F) FOR ANY AMOUNTS THAT, TOGETHER WITH AMOUNTS ASSOCIATED WITH ALL OTHER CLAIMS, EXCEED THE FEES PAID AND/OR PAYABLE BY CUSTOMER TO FLOCK FOR THE SERVICES UNDER THIS AGREEMENT IN THE TWELVE (12) MONTHS PRIOR TO THE ACT OR OMISSION THAT GAVE RISE TO THE LIABILITY, IN EACH CASE, WHETHER OR NOT FLOCK HAS BEEN ADVISED OF THE POSSIBILITY OF SUCH DAMAGES. THIS LIMITATION OF LIABILITY OF SECTION ONLY APPLIES TO THE EXTENT ALLOWED BY THE GOVERNING LAW OF THE STATE REFERENCED IN SECTION

11.6. NOTWITHSTANDING ANYTHING TO THE CONTRARY, THE FOREGOING LIMITATIONS OF LIABILITY SHALL NOT APPLY (I) IN THE EVENT OF GROSS NEGLIGENCE OR WILLFUL MISCONDUCT, OR (II) INDEMNIFICATION OBLIGATIONS.

9.2 **Responsibility.** Each Party to this Agreement shall assume the responsibility and liability for the acts and omissions of its own employees, officers, or agents, in connection with the performance of their official duties under this Agreement. Each Party to this Agreement shall be liable for the torts of its own officers, agents, or employees.

9.3 **Flock Indemnity.** Flock shall indemnify and hold harmless Customer, its agents and employees, from liability of any kind, including claims, costs (including defense) and expenses, on account of: (i) any copyrighted material, patented or unpatented invention, articles, device or appliance manufactured or used in the performance of this Agreement; or (ii) any damage or injury to property or person directly caused by Flock's installation of Flock Hardware, except for where such damage or injury was caused solely by the negligence of the Customer or its agents, officers or employees. Flock's performance of this indemnity obligation shall not exceed the fees paid and/or payable for the services rendered under this Agreement in the preceding twelve (12) months.

10. INSTALLATION SERVICES AND OBLIGATIONS

10.1 **Ownership of Hardware.** Flock Hardware is owned and shall remain the exclusive property of Flock. Title to any Flock Hardware shall not pass to Customer upon execution of this Agreement, except as otherwise specifically set forth in this Agreement. Except as otherwise expressly stated in this Agreement, Customer is not permitted to remove, reposition, re-install, tamper with, alter, adjust or otherwise take possession or control of Flock Hardware. Customer agrees and understands that in the event Customer is found to engage in any of the foregoing restricted actions, all warranties herein shall be null and void, and this Agreement shall be subject to immediate termination for material breach by Customer. Customer shall not perform any acts which would interfere with the retention of title of the Flock Hardware by Flock. Should Customer default on any payment of the Flock Services, Flock may remove Flock Hardware at Flock's discretion. Such removal, if made by Flock, shall not be deemed a waiver of Flock's

rights to any damages Flock may sustain as a result of Customer's default and Flock shall have the right to enforce any other legal remedy or right.

10.2 Deployment Plan. Flock shall advise Customer on the location and positioning of the Flock Hardware for optimal product functionality, as conditions and locations allow. Flock will collaborate with Customer to design the strategic geographic mapping of the location(s) and implementation of Flock Hardware to create a deployment plan ("**Deployment Plan**"). In the event that Flock determines that Flock Hardware will not achieve optimal functionality at a designated location, Flock shall have final discretion to veto a specific location, and will provide alternative options to Customer.

10.3 Changes to Deployment Plan. After installation of Flock Hardware, any subsequent requested changes to the Deployment Plan, including, but not limited to, relocating, re-positioning, adjusting of the mounting, removing foliage, replacement, changes to heights of poles will incur a fee according to the reinstall fee schedule located at (<https://www.flocksafety.com/reinstall-fee-schedule>). Customer will receive prior notice and confirm approval of any such fees.

10.4 Customer Installation Obligations. Customer is responsible for any applicable supplementary cost as described in the Customer Implementation Guide, attached hereto as Exhibit C. Customer represents and warrants that it has, or shall lawfully obtain, all necessary right title and authority and hereby authorizes Flock to install the Flock Hardware at the designated locations and to make any necessary inspections or maintenance in connection with such installation.

10.5 Flock's Obligations. Installation of any Flock Hardware shall be installed in a professional manner within a commercially reasonable time from the Effective Date of this Agreement. Upon removal of Flock Hardware, Flock shall restore the location to its original condition, ordinary wear and tear excepted. Flock will continue to monitor the performance of Flock Hardware for the length of the Term. Flock may use a subcontractor or third party to perform certain obligations under this Agreement, provided that Flock's use of such subcontractor or third party shall not release Flock from any duty or liability to fulfill Flock's obligations under this Agreement.

11. MISCELLANEOUS

11.1 Compliance With Laws. Parties shall comply with all applicable local, state and federal laws, regulations, policies and ordinances and their associated record retention schedules, including responding to any subpoena request(s).

11.2 Severability. If any provision of this Agreement is found to be unenforceable or invalid, that provision will be limited or eliminated to the minimum extent necessary so that this Agreement will otherwise remain in full force and effect.

11.3 Assignment. This Agreement is not assignable, transferable or sublicensable by either Party, without prior consent. Notwithstanding the foregoing, either Party may assign this Agreement, without the other Party's consent, (i) to any parent, subsidiary, or affiliate entity, or (ii) to any purchaser of all or substantially all of such Party's assets or to any successor by way of merger, consolidation or similar transaction.

11.4 Entire Agreement. This Agreement, together with the Order Form(s), the reinstall fee schedule (<https://www.flocksafety.com/reinstall-fee-schedule>), and any attached exhibits are the complete and exclusive statement of the mutual understanding of the Parties and supersedes and cancels all previous or contemporaneous negotiations, discussions or agreements, whether written and oral, communications and other understandings relating to the subject matter of this Agreement. All waivers and modifications must be in a writing signed by both Parties, except as otherwise provided herein. None of Customer's purchase orders, authorizations or similar documents will alter the terms of this Agreement, and any such conflicting terms are expressly rejected. Any mutually agreed upon future purchase order is subject to these legal terms and does not alter the rights and obligations under this Agreement, except that future purchase orders may outline additional products, services, quantities and billing terms to be mutually accepted by Parties. In the event of any conflict of terms found in this Agreement or any other terms and conditions, the terms of this Agreement shall prevail. Customer agrees that Customer's purchase is neither contingent upon the delivery of any future functionality or features nor dependent upon any oral or written comments made by Flock with respect to future functionality or feature.

11.5 Relationship. No agency, partnership, joint venture, or employment is created as a result of this Agreement and Parties do not have any authority of any kind to bind each other in any respect whatsoever. Flock shall at all times be and act as an independent contractor to Customer.

11.6 Governing Law; Venue. This Agreement shall be governed by the laws of the state in which the Customer is located. The Parties hereto agree that venue would be proper in the

chosen courts of the State of which the Customer is located. The Parties agree that the United Nations Convention for the International Sale of Goods is excluded in its entirety from this Agreement.

11.7 Special Terms. Flock may offer certain special terms which are indicated in the Order Form and will become part of this Agreement, upon Customer's prior written consent and the mutual execution by authorized representatives ("Special Terms"). To the extent that any terms of this Agreement are inconsistent or conflict with the Special Terms, the Special Terms shall control.

11.8 Publicity. Upon prior written consent, Flock has the right to reference and use Customer's name and disclose the nature of the Services in business and development and marketing efforts. Nothing contained in this Agreement shall be construed as conferring on any Party, any right to use the other Party's name as an endorsement of product/service.

11.9 Feedback. If Customer or Authorized End User provides any suggestions, ideas, enhancement requests, feedback, recommendations or other information relating to the subject matter hereunder, Agency or Authorized End User hereby assigns to Flock all right, title and interest (including intellectual property rights) with respect to or resulting from any of the foregoing.

11.10 Export. Customer may not remove or export from the United States or allow the export or re-export of the Flock IP or anything related thereto, or any direct product thereof in violation of any restrictions, laws or regulations of the United States Department of Commerce, the United States Department of Treasury Office of Foreign Assets Control, or any other United States or foreign Customer or authority. As defined in Federal Acquisition Regulation ("FAR"), section 2.101, the Services, the Flock Hardware and Documentation are "commercial items" and according to the Department of Defense Federal Acquisition Regulation ("DFAR") section 252.2277014(a)(1) and are deemed to be "commercial computer software" and "commercial computer software documentation." Flock is compliant with FAR Section 889 and does not contract or do business with, use any equipment, system, or service that uses the enumerated banned Chinese telecommunication companies, equipment or services as a substantial or essential component of any system, or as critical technology as part of any Flock system. Consistent with DFAR section 227.7202 and FAR section 12.212, any use, modification, reproduction, release, performance, display, or disclosure of such commercial software or

commercial software documentation by the U.S. Government will be governed solely by the terms of this Agreement and will be prohibited except to the extent expressly permitted by the terms of this Agreement.

11.11 **Headings.** The headings are merely for organization and should not be construed as adding meaning to the Agreement or interpreting the associated sections.

11.12 **Authority.** Each of the below signers of this Agreement represent that they understand this Agreement and have the authority to sign on behalf of and bind the Parties they are representing upon the Effective Date.

11.13 **Conflict.** In the event there is a conflict between this Agreement and any applicable statement of work, or Customer purchase order, this Agreement controls unless explicitly stated otherwise.

11.14 **Notices.** All notices under this Agreement will be in writing and will be deemed to have been duly given when received, if personally delivered; when receipt is electronically confirmed, if transmitted by email; the day after it is sent, if sent for next day delivery by recognized overnight delivery service; and upon receipt to the address listed on the Order Form (or, if different, below), if sent by certified or registered mail, return receipt requested.

11.15 **Non-Appropriation.** Notwithstanding any other provision of this Agreement, all obligations of the Customer under this Agreement which require the expenditure of public funds are conditioned on the availability of said funds appropriated for that purpose. To the extent applicable, Customer shall have the right to terminate this Agreement for non appropriation with thirty (30) days written notice without penalty or other cost.

FLOCK NOTICES ADDRESS:

1170 HOWELL MILL ROAD, NW SUITE 210

ATLANTA, GA 30318

ATTN: LEGAL DEPARTMENT

EMAIL: legal@flocksafety.com

Customer NOTICES ADDRESS:

ADDRESS:

ATTN:

EMAIL:

EXHIBIT B
INSURANCE

Required Coverage. Flock shall procure and maintain for the duration of this Agreement insurance against claims for injuries to persons or damages to property that may arise from or in connection with the performance of the services under this Agreement and the results of that work by Flock or its agents, representatives, employees or subcontractors. Insurance shall be placed with insurers with a current A. M. Best rating of no less than "A" and "VII". Flock shall obtain and, during the term of this Agreement, shall maintain policies of professional liability (errors and omissions), automobile liability, and general liability insurance for insurable amounts of not less than the limits listed herein. The insurance policies shall provide that the policies shall remain in full force during the life of the Agreement. Flock shall procure and shall maintain during the life of this Agreement Worker's Compensation insurance as required by applicable State law for all Flock employees. For the avoidance of doubt, (i) all required insurance limits by Customer can be met through a combination of primary and excess umbrella coverage, and (ii) Flock's Cyber and Errors and Omissions insurance has a shared limit of Five Million Dollars (5,000,000) per incident and in the aggregate.

Types and Amounts Required. Flock shall maintain, at minimum, the following insurance coverage for the duration of this Agreement:

- (i) **Commercial General Liability** insurance written on an occurrence basis with minimum limits of One Million Dollars (\$1,000,000) per occurrence and Two Million Dollars (\$2,000,000) in the aggregate for bodily injury, death, and property damage, including personal injury, contractual liability, independent contractors, broad-form property damage, and product and completed operations coverage;
- (ii) **Workers Compensation** insurance in accordance with statutory limits;
- (iii) **Professional Liability/Errors and Omissions** insurance with minimum limits of Five Million Dollars (\$5,000,000) per occurrence and Five Million Dollars (\$5,000,000) in the aggregate;

(iv) **Commercial Automobile Liability** insurance with a minimum combined single limit of One Million Dollars (\$1,000,000) per occurrence for bodily injury, death, and property coverage, including owned and non-owned and hired automobile coverage; and

(v) **Cyber Liability** insurance written on an occurrence basis with minimum limits of Five Million Dollars (\$5,000,000).



Elkton Police Department

173 West Spotswood Avenue, Elkton, VA 22827

Phone: 540-298-9441

Fax: 540-298-9499

Email: elktonpd@townofelkton.com

Michael L. King
Chief of Police

TOWN OF ELKTON



VIRGINIA
INCORPORATED 1908

Property License Agreement

I, John W. Morris Jr, the owner/agent of [Address] 334 S. East Side Hwy ("Property") represent and warrant that I have the authority to enter into this Property License Agreement ("Agreement") and hereby grant Flock Group Inc. ("Flock Safety") a license to install and maintain ("Services") a camera or cameras ("Flock Hardware") on the Property on behalf of Elkton Police Department.

I understand and acknowledge that Flock Hardware is the sole property of Flock Safety and, by signing this Agreement, represent and warrant that I shall not tamper with or attempt to gain access to Flock Hardware nor interfere with Services.

Further, except for my own gross negligence or willful misconduct, Flock Safety shall indemnify me and hold me harmless from all claims, suits, or actions of every name, kind, and description, brought for, or on account of: (A) injuries to or death of any person resulting from Flock Hardware or Services, (B) damage to the Property resulting from Flock Hardware or providing Services during the ordinary course of business, and (C) any other loss or cost resulting from the performance of any work required by Flock Safety related to Flock Hardware, Services or payments by Customer to Flock Safety for work rendered.

I understand that this Agreement is revocable by me at any time, provided that I (1) issue Flock Safety thirty (30) days written notice via email to support@flocksafety.com, and (2) allow Flock Safety to enter the Property and safely remove all Flock Hardware from the Property without interference.

Signed, John W. Morris Jr.

Name: John W. Morris Jr.

Address/Business: 334 S. East Side Hwy
Elkton, Va. 22827

Phone: (540) 280-8015

COMMERCIAL - INDUSTRIAL - AUTOMATION
SYSTEMS INTEGRATION
DESIGN BUILD
NETWORKING/FIBER OPTIC
PC/SERVER SUPPORT

Class A Electrical Contractor
ALLEN YOHO ELECTRICAL, INC.
Mel Lemon - Chief Financial Officer

334 S. Eastside Hwy.
Elkton, VA 22827

Email: mel.lemon@aye-inc.com

website: www.aye-inc.com

Cell: (540) 820-4150

Office: (540) 949-6782

Fax: (540) 949-6784

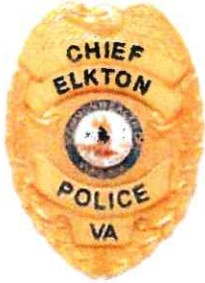

Elkton Police Department

173 West Spotswood Avenue, Elkton, VA 22827

Phone: 540-298-9441

Fax: 540-298-9499

Email: elktonpd@townofelkton.com

Michael L. King
Chief of Police

TOWN OF ELKTON



VIRGINIA
INCORPORATED 1908

Property License Agreement

I, Michael Lucci, the owner/agent of [Address] Good Fellows
("Property") represent and warrant that I have the authority to enter into this Property License Agreement
("Agreement") and hereby grant Flock Group Inc. ("Flock Safety") a license to install and maintain ("Services")
a camera or cameras ("Flock Hardware") on the Property on behalf of Elkton Police Department.

I understand and acknowledge that Flock Hardware is the sole property of Flock Safety and, by signing this Agreement, represent and warrant that I shall not tamper with or attempt to gain access to Flock Hardware nor interfere with Services.

Further, except for my own gross negligence or willful misconduct, Flock Safety shall indemnify me and hold me harmless from all claims, suits, or actions of every name, kind, and description, brought for, or on account of: (A) injuries to or death of any person resulting from Flock Hardware or Services, (B) damage to the Property resulting from Flock Hardware or providing Services during the ordinary course of business, and (C) any other loss or cost resulting from the performance of any work required by Flock Safety related to Flock Hardware, Services or payments by Customer to Flock Safety for work rendered.

I understand that this Agreement is revocable by me at any time, provided that I (1) issue Flock Safety thirty (30) days written notice via email to support@flocksafety.com, and (2) allow Flock Safety to enter the Property and safely remove all Flock Hardware from the Property without interference.

Signed, [Signature]

Name: Michael Lucci

Address/Business: 100 South Stuger Ave
Elkton VA 22827

Phone: 540 298 1001



Elkton Police Department

173 West Spotswood Avenue, Elkton, VA 22827

Phone: 540-298-9441

Fax: 540-298-9499

Email: elktonpd@townofelkton.com

TOWN OF ELKTON



VIRGINIA
INCORPORATED 1908

Michael L. King
Chief of Police

Property License Agreement

I, Michele Lucci, the owner/agent of [Address] Ciros Italia Eatery ("Property") represent and warrant that I have the authority to enter into this Property License Agreement ("Agreement") and hereby grant Flock Group Inc. ("Flock Safety") a license to install and maintain ("Services") a camera or cameras ("Flock Hardware") on the Property on behalf of Elkton Police Department.

I understand and acknowledge that Flock Hardware is the sole property of Flock Safety and, by signing this Agreement, represent and warrant that I shall not tamper with or attempt to gain access to Flock Hardware nor interfere with Services.

Further, except for my own gross negligence or willful misconduct, Flock Safety shall indemnify me and hold me harmless from all claims, suits, or actions of every name, kind, and description, brought for, or on account of: (A) injuries to or death of any person resulting from Flock Hardware or Services, (B) damage to the Property resulting from Flock Hardware or providing Services during the ordinary course of business, and (C) any other loss or cost resulting from the performance of any work required by Flock Safety related to Flock Hardware, Services or payments by Customer to Flock Safety for work rendered.

I understand that this Agreement is revocable by me at any time, provided that I (1) issue Flock Safety thirty (30) days written notice via email to support@flocksafety.com, and (2) allow Flock Safety to enter the Property and safely remove all Flock Hardware from the Property without interference.

Signed, [Signature]

Name: Michele Lucci

Address/Business: 101 Downey Knoll DR
ELKTON VA 22827

Phone: 540-298-1205



COMMONWEALTH OF VIRGINIA

Colonel Matthew D. Hanley
Superintendent

(804) 674-2000

DEPARTMENT OF STATE POLICE

P. O. Box 27472, Richmond, VA 23261-7472

Lt. Colonel Keenon C. Hook
Deputy Superintendent

July 1, 2025

Dear Chief/Sheriff,

Beginning in 2022, the Department approved the first ever allocation of funding to reimburse Virginia law enforcement agencies for the cost of purchasing equipment, software, and/or training to be used for the investigation and/or prevention of motor vehicle theft and the theft of motor vehicle parts. This annual initiative has proven to be very successful as more than 250 agencies have been able to take advantage of this funding. I am especially pleased to see that, in part due to this funding, motor vehicle thefts *decreased* again last year, clearly indicating that this initiative has had a meaningful and measurable impact in communities across the state.

Therefore, I am pleased to announce that beginning July 1, 2025, the Help Eliminate Auto Theft (HEAT) program is allocating financial support of **up to \$10,000 per agency** to reimburse agencies for the purchase of equipment, software, and/or training that will be used for investigating or preventing motor vehicle theft. Please note that all funding will be allocated on a first-come basis.

To receive this funding, please review and complete the attached application and email it to First Sergeant Peter W. Lazear, HEAT Program Statewide Coordinator, at peter.lazear@vsp.virginia.gov. After careful review of your application, you will be notified if your request is approved for reimbursement. Once your agency has completed your purchase, please send a copy of the receipt to First Sergeant Lazear. At that time, he will release payment to your agency according to your Federal Identification Number.

If you desire additional information regarding this FY26 HEAT Equipment Reimbursement, please feel free to contact First Sergeant Lazear by email or cell phone at (804) 221-0997. Your continued partnership with the HEAT program is greatly appreciated.

Sincerely,

A handwritten signature in black ink, appearing to read "M. Hanley", with a long horizontal flourish extending to the right.

Matthew D. Hanley
Superintendent

Ryan Insana

From: Ryan Insana
Sent: Wednesday, December 11, 2024 2:15 PM
To: Donna Curry
Subject: FW: Elkton Police Department HEAT GRANT

Just for your records. Email chain between us and VSP about repayment of the grant for the cameras.

Ryan

From: Lazear, Peter (VSP) <peter.lazear@vsp.virginia.gov>
Sent: Wednesday, December 11, 2024 2:04 PM
To: Ryan Insana <rinsana@townofelkton.com>
Subject: Re: Elkton Police Department HEAT GRANT

Thank you for the prompt reply and for sending your supporting documentation. I have submitted a payment request to my Property & Finance Division in the amount of \$12,300 to your agency. Please allow several weeks for the payment to be processed.

I hope the Flock equipment serves your community well!

Sincerely,
Peter

First Sergeant Peter W. Lazear

Statewide Program Coordinator

President - International Association of Auto Theft Investigators - Southeast Chapter

Virginia Department of State Police

Help Eliminate Auto Theft

Insurance Fraud Program

7700 Midlothian Turnpike

N. Chesterfield, VA 23235-5226

Cell: ---

www.HEATreward.com (-> heatreward.com)

www.StampOutFraud.com

The information in this email and any attachments may be confidential and privileged. Access to this email by anyone other than the intended addressee is unauthorized. If you are not the intended recipient (or the employee or agent responsible for delivering this information to the intended recipient) please notify the sender by reply email and immediately delete this email and any copies from your computer and/or storage system. The sender does not authorize the use, distribution, disclosure or reproduction of this email (or any part of its contents) by anyone other than the intended recipient(s). No representation is made that this

email and any attachments are free of viruses. Virus scanning is recommended and is the responsibility of the recipient.

From: Ryan Insana <rinsana@townofelkton.com>
Sent: Wednesday, December 11, 2024 1:21 PM
To: Lazear, Peter (VSP) <peter.lazear@vsp.virginia.gov>
Subject: Re: Elkton Police Department HEAT GRANT

Hello Sir,

Yes I am ok with the extra money going to another department. Thank you.

Sergeant Ryan M. Insana
Explosive K9 Handler
Town of Elkton Police Department
173 W. Spotswood Ave.
Elkton, VA 22827
Cell: 540-435-2053
Office: 540-298-9441
Fax: 540-298-9499

On Dec 11, 2024, at 12:09 PM, Lazear, Peter (VSP) <peter.lazear@vsp.virginia.gov> wrote:

Good Afternoon,

This receipt is, indeed, all I need. However, before I proceed, I just wanted to confirm because your application requested \$12,500 but your receipt is for \$12,300. Are you okay with me re-allocating your remaining \$200 to another law enforcement agency?

Thanks in advance,
Peter

First Sergeant Peter W. Lazear

Statewide Program Coordinator

President - International Association of Auto Theft Investigators - Southeast Chapter

Virginia Department of State Police

Help Eliminate Auto Theft

Insurance Fraud Program

7700 Midlothian Turnpike

N. Chesterfield, VA 23235-5226

Cell.

www.HEATreward.com (-> heatreward.com)

www.StampOutFraud.com

The information in this email and any attachments may be confidential and privileged. Access to this email by anyone other than the intended addressee is unauthorized. If you are not the intended recipient (or the employee or agent responsible for delivering this information to the intended recipient) please notify the sender by reply email and immediately delete this email and any copies from your computer and/or storage system. The sender does not authorize the use, distribution, disclosure or reproduction of this email (or any part of its contents) by anyone other than the intended recipient(s). No representation is made that this email and any attachments are free of viruses. Virus scanning is recommended and is the responsibility of the recipient.

From: Ryan Insana <rinsana@townofelkton.com>
Sent: Monday, December 9, 2024 10:24 AM
To: Lazear, Peter (VSP) <peter.lazear@vsp.virginia.gov>
Subject: Elkton Police Department HEAT GRANT

Good Morning First Sergeant Lazear,

Sir, here is our invoice from FLOCK and the check that we sent them for payment from the Town. According to your email that was all that you needed on our end. If you need any additional information please reach out and I will get it to you as soon as possible. Thank you for your time on this.

Respectfully,

Sergeant Ryan M. Insana
Explosive K9 Handler
Town of Elkton Police Department
173 W. Spotswood Ave.
Elkton, VA 22827
Cell: 540-435-2053
Office: 540-298-9441
Fax: 540-298-9499

<image001.png>

From: copier@townofelkton.com <copier@townofelkton.com>
Sent: Monday, December 9, 2024 11:00 AM
To: Ryan Insana <rinsana@townofelkton.com>
Subject: Message from KM_C3350i

Ryan Insana

From: Ryan Insana
Sent: Tuesday, October 8, 2024 3:16 PM
To: Brandon Williams
Subject: RE: Flock Safety <> Elkton PD <> Intro Follow Up

Hey Brandon,

I just wanted to give you an update on our grant, we just got notified today that we will receive the full funding of 12,500.00.

Ryan Insana

From: Brandon Williams <brandon.williams@flocksafety.com>
Sent: Thursday, October 3, 2024 10:22 AM
To: Ryan Insana <rinsana@townofelkton.com>
Subject: Flock Safety <> Elkton PD <> Intro Follow Up

Sergeant Insana,

It was great getting to speak with you yesterday. Below are links to short videos around the main Flock products we discussed and attached is a high level overview of Flock.

What I heard from the conversation...

- Drug trafficking & other vehicle related crime has increased which has created a need for LPRs
- Vandalism in the local cemetery has created a need for Live Video cameras
- Do get tips from neighboring agencies who have Flock about vehicles of interest
- Applied for the HEAT grant to potentially fund Flock

How Flock can help....

- [Flock Safety Falcon LPR](#)
- [Flock Safety Condor Live Video](#)
- [FlockOS](#) - Alerts, vehicle look up, mapping, & live LPR/Video footage that can be accessed on any device
- Access to all Flock cameras in VA & USA

Next Steps...

- Strategy/Mapping call on 10/17

Let me know if there are any questions whatsoever and we look forward to continuing our conversations,

--

Brandon Williams

Territory Sales Manager, Local Markets



flocksafety.com

flock safety



Ryan Insana

From: Ryan Insana
Sent: Tuesday, October 8, 2024 3:19 PM
To: Greg Lunsford
Subject: FW: Flock Safety <> Elkton PD <> Intro Follow Up
Attachments: Why Flock Safety - Overview (1).pdf

Hi Greg,

Here is some reading on the products that we are looking at, just in case anyone is ever to ask about it.

Ryan

From: Brandon Williams <brandon.williams@flocksafety.com>
Sent: Thursday, October 3, 2024 10:22 AM
To: Ryan Insana <rinsana@townofelkton.com>
Subject: Flock Safety <> Elkton PD <> Intro Follow Up

Sergeant Insana,

It was great getting to speak with you yesterday. Below are links to short videos around the main Flock products we discussed and attached is a high level overview of Flock.

What I heard from the conversation...

- Drug trafficking & other vehicle related crime has increased which has created a need for LPRs
- Vandalism in the local cemetery has created a need for Live Video cameras
- Do get tips from neighboring agencies who have Flock about vehicles of interest
- Applied for the HEAT grant to potentially fund Flock

How Flock can help....

- [Flock Safety Falcon LPR](#)
- [Flock Safety Condor Live Video](#)
- [FlockOS](#) - Alerts, vehicle look up, mapping, & live LPR/Video footage that can be accessed on any device
- Access to all Flock cameras in VA & USA

Next Steps...

- Strategy/Mapping call on 10/17

Let me know if there are any questions whatsoever and we look forward to continuing our conversations,

--

Brandon Williams

Territory Sales Manager, Local Markets



flocksafety.com

flock safety



Ryan Insana

From: Brandon Williams <brandon.williams@flocksafety.com>
Sent: Thursday, October 31, 2024 1:25 PM
To: Ryan Insana; Michael King
Subject: Re: Flock Safety <> Elkton PD <> Intro Follow Up
Attachments: Private Property Permission.docx.pdf; VA - Elkton PD - Law Enforcement Agreement - (1).pdf

Chief King & Sergeant Insana,

As always, it was great getting to connect again yesterday and I am glad that we were able to find locations where we won't have any issues with VDOT.

Below is a screen shot of the updated map.

- The far left red icon is the Falcon Long Range LPR
- The red icon on S 33 is a standard Falcon LPR
- The blue icon north on 33 is a Condor Live Video PTZ - I did confirm that the new solar PTZs are the same price as the AC power so we do have options

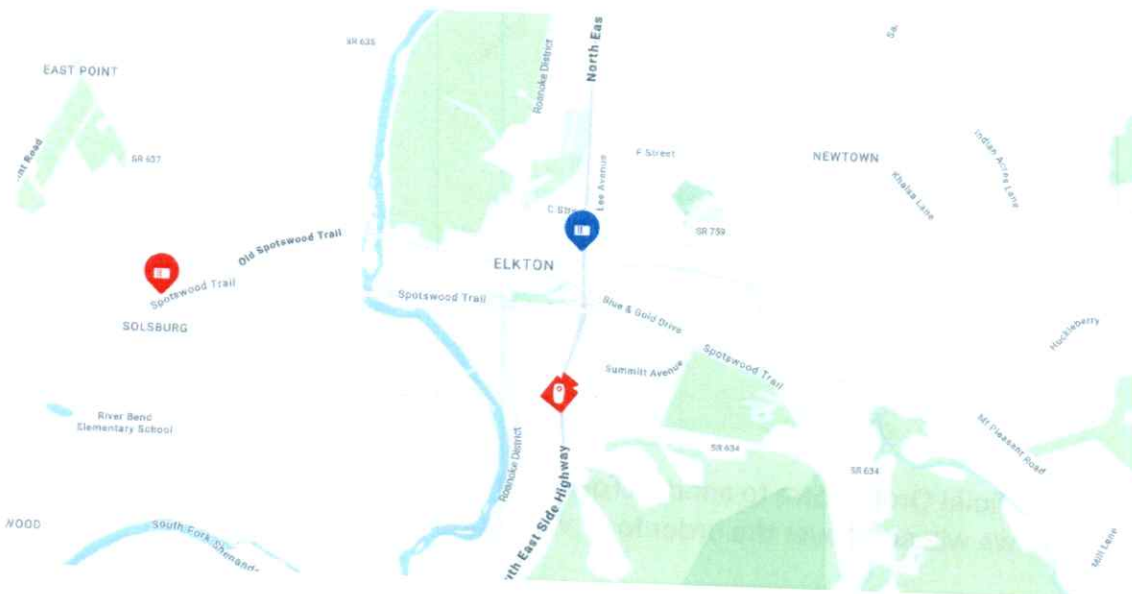

Attached is the updated order form and a private property consent form for when you approach the private property location that we picked out.

You will notice that the recurring cost went down to \$11,000 per year vs the original quote of \$12,000.

I wasn't able to get approval to wave the install fee but we still fall within the HEAT Grant budget.

I did get the items that you all's lawyer flagged for additional clarity and my legal team is reviewing as we speak so will keep you all updated on that.

Please let me know if there are any additional questions and/or anything else needed from me on my end.

I look forward to connecting again early next week to see where we are at with everything and solidifying our partnership!

On Fri, Oct 25, 2024 at 10:10 AM Brandon Williams <brandon.williams@flocksafety.com> wrote:
Chief King & Sergeant Insana,

It was great getting to speak with you both yesterday.

Below is a screen shot of the locations that we confirmed - once my Project Management team approves on our end I'll be sending over a link for you all to officially approve the locations as well. - This gives us some time for you both to speak with Public Works.



Attached is the MSA and the official Order Form to send to Town Manager Greg Lunsford for review. Once everything is good to go we will send over the order form via DocuSign for e-signature.

Let me know if there are any questions whatsoever and we look forward to connecting again next week to see where everything is at.

Have a great Friday and weekend,

On Fri, Oct 18, 2024 at 12:32 PM Brandon Williams <brandon.williams@flocksafety.com> wrote:
Chief King & Sergeant Insana,

It was great getting to speak with you both yesterday.

Below is a screen shot of the map that we talked through. You'll notice that it has 4 Falcons & 2 Condors. (Falcon LPRs in Red - Live Video Condors in Blue)

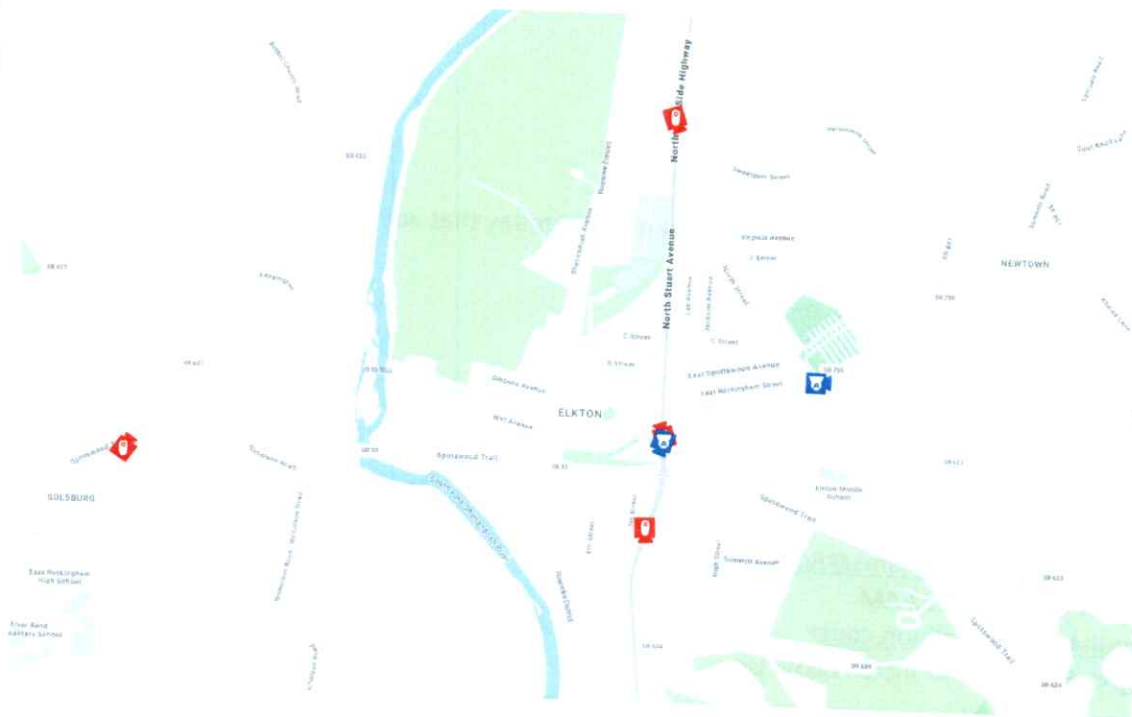

These are the 6 locations that we discussed (Falcon LPRs in red, Live Video Condors in Blue) so what we need to do from here is narrow it down to fall within the HEAT grant budget of \$12,000 which would be 4 cameras.

When we parted ways yesterday you both felt like it made the most sense to have a Falcon LPR on 33 by the Food Lion, two Falcon LPRs on 340 going N & S, and a Live Video Condor at the main intersection on Spottswood/Stuart.

As we discussed, 33 and 340 are VDOT right of ways so depending on what your contact over there comes back with, we will likely need to try to find private property off the right of way which my Deployment Specialist will be able to do on our call next week. He will also be able to confirm how many lanes of traffic the LPR will be able to capture based on the location of the camera.

Let me know if there are any questions whatsoever and we look forward to continuing the conversations next week,

On Tue, Oct 8, 2024 at 3:43 PM Brandon Williams <brandon.williams@flocksafety.com> wrote:
Ryan,

That is great news.

On our next call we will talk through and confirm the locations of the cameras.

Did they say when you all will have access to the funds?

On Tue, Oct 8, 2024 at 3:16 PM Ryan Insana <rinsana@townofelkton.com> wrote:

Hey Brandon,

I just wanted to give you an update on our grant, we just got notified today that we will receive the full funding of 12,500.00.

Ryan Insana

From: Brandon Williams <brandon.williams@flocksafety.com>
Sent: Thursday, October 3, 2024 10:22 AM
To: Ryan Insana <rinsana@townofelkton.com>
Subject: Flock Safety <> Elkton PD <> Intro Follow Up

Sergeant Insana,

It was great getting to speak with you yesterday. Below are links to short videos around the main Flock products we discussed and attached is a high level overview of Flock.

What I heard from the conversation...

- Drug trafficking & other vehicle related crime has increased which has created a need for LPRs
- Vandalism in the local cemetery has created a need for Live Video cameras
- Do get tips from neighboring agencies who have Flock about vehicles of interest
- Applied for the HEAT grant to potentially fund Flock

How Flock can help....

- [Flock Safety Falcon LPR](#)
- [Flock Safety Condor Live Video](#)
- [FlockOS](#) - Alerts, vehicle look up, mapping, & live LPR/Video footage that can be accessed on any device

- Access to all Flock cameras in VA & USA

Next Steps...

- Strategy/Mapping call on 10/17

Let me know if there are any questions whatsoever and we look forward to continuing our conversations,

--

Brandon Williams

Territory Sales Manager, Local Markets

flocksafety.com

--

Brandon Williams

Territory Sales Manager, Local Markets

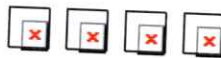

 flocksafety.com



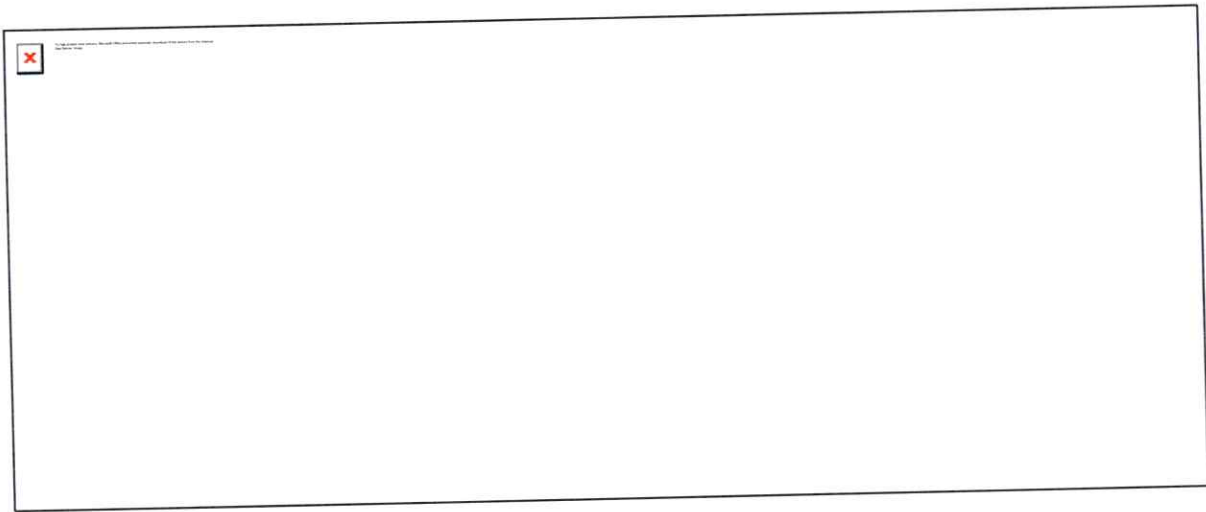

Brandon Williams
Territory Sales Manager, Local Markets



 flocksafty.com

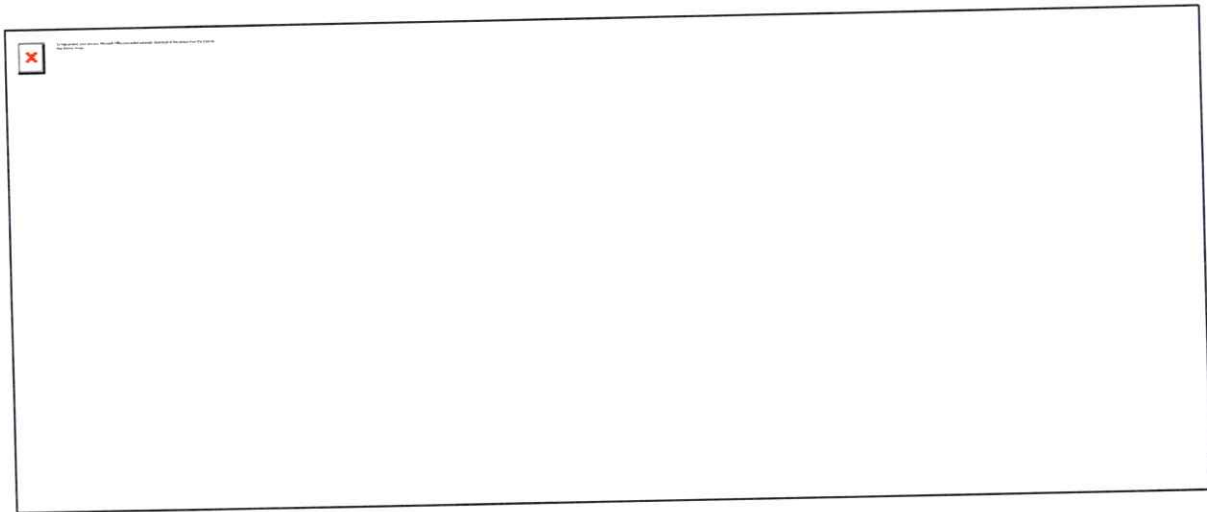

--

Brandon Williams

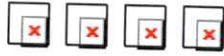

Territory Sales Manager, Local Markets

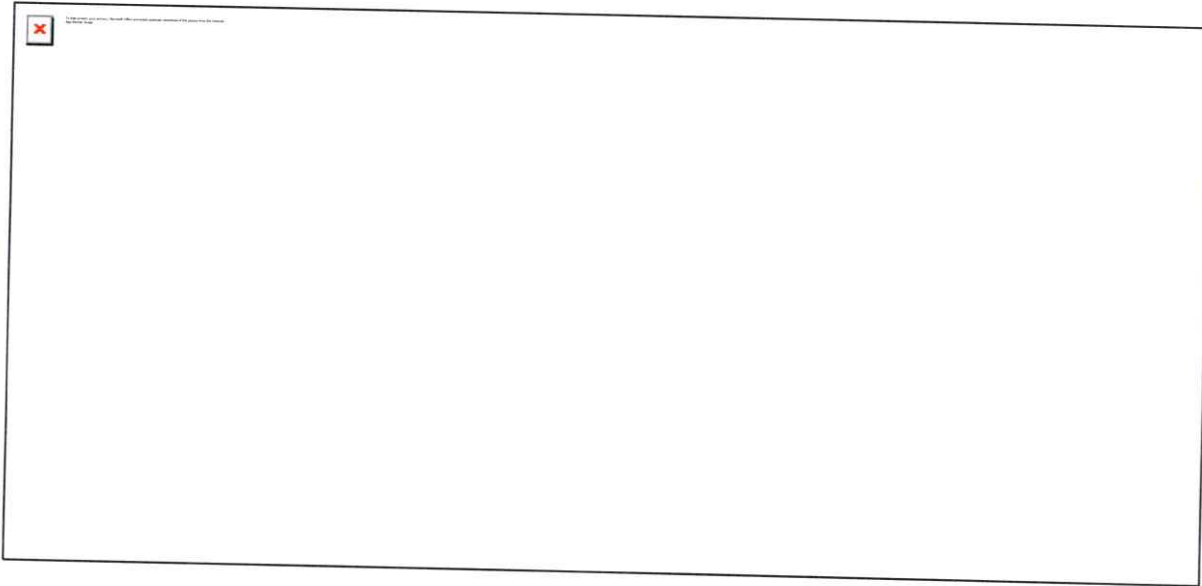
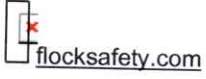

--

Brandon Williams

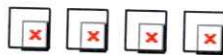

Territory Sales Manager, Local Markets

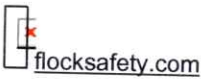

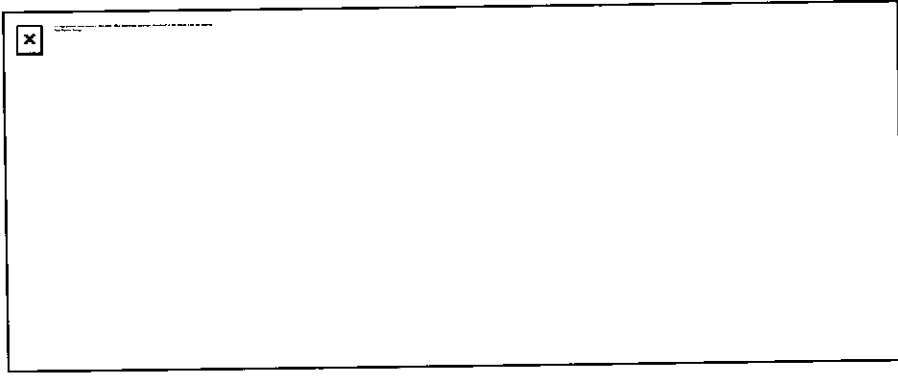

Ryan Insana

From: Greg Lunsford
Sent: Tuesday, November 12, 2024 10:42 AM
To: Brandon Williams
Cc: Michael King; Ryan Insana
Subject: RE: Action Required | VA - Elkton PD - Law Enforcement Agreement | Pending Signature
Attachments: VA - Elkton PD - Law Enforcement Agreement - (2).pdf

Brandon,

I just want to confirm that we will be billed \$12,300 now and the follow-up \$11,000 annual recurring costs will be billed a year from now?

Thanks,

Greg Lunsford
Town Manager
Town of Elkton, VA
540-787-0189

From: Brandon Williams <brandon.williams@flocksafety.com>
Sent: Tuesday, November 12, 2024 9:36 AM
To: Greg Lunsford <glunsford@townofelkton.com>
Subject: Re: Action Required | VA - Elkton PD - Law Enforcement Agreement | Pending Signature

No problem.

The PDF version of the order form is attached.

Let me know if you need anything else from me on my end,

On Tue, Nov 12, 2024 at 9:07 AM Greg Lunsford <glunsford@townofelkton.com> wrote:

Brandon,

Can you please send the document as an attachment that I can print and sign manually and return.

Thank you,

Greg Lunsford

Town Manager

Town of Elkton, VA

540-787-0189

From: Flock Safety <contracts@DocuSign.Flocksafety.com>

Sent: Tuesday, November 12, 2024 9:04 AM

To: Greg Lunsford <glunsford@townofelkton.com>

Subject: Action Required | VA - Elkton PD - Law Enforcement Agreement | Pending Signature

Brandon Williams sent you a document to review and sign.

[REVIEW DOCUMENTS](#)

Brandon Williams

brandon.williams@flocksafety.com

Hi,

The VA - Elkton PD - Law Enforcement Agreement has been routed to you for signature. Please select the link above to access the agreement and sign in the designated areas.

Thanks!

Powered by

Do Not Share This Email

This email contains a secure link to DocuSign. Please do not share this email, link, or access code with others.

Alternate Signing Method

Visit DocuSign.com, click 'Access Documents', and enter the security code:
7C9852788C034AF1AFC40C32E2EE39657

About DocuSign

Sign documents electronically in just minutes. It's safe, secure, and legally binding. Whether you're in an office, at home, on-the-go -- or even across the globe -- DocuSign provides a professional trusted solution for Digital Transaction Management™.

Questions about the Document?

If you need to modify the document or have questions about the details in the document, please reach out to the sender by emailing them directly.

Stop receiving this email

[Report this email](#) or read more about [Declining to sign](#) and [Managing notifications](#).

If you have trouble signing, visit "[How to Sign a Document](#)" on our [DocuSign Support Center](#), or browse our [DocuSign Community](#) for more information.

[Download the DocuSign App](#)

This message was sent to you by Brandon Williams who is using the DocuSign Electronic Signature Service. If you would rather not receive email from this sender you may contact the sender with your request.

Brandon Williams

Territory Sales Manager, Local Markets



flocksafety.com

flock safety

JOIN OUR LIVE WEBINAR

The Next Frontier in Policing: **Introducing Flock Safety's Drones** for Rapid Response

NOVEMBER 13TH • 1 PM ET / 10 AM PT

Ryan Insana

From: Brandon Williams <brandon.williams@flocksafety.com>
Sent: Tuesday, November 12, 2024 10:46 AM
To: Greg Lunsford
Cc: Michael King; Ryan Insana
Subject: Re: Action Required | VA - Elkton PD - Law Enforcement Agreement | Pending Signature

You are correct,

Brandon Williams
Territory Sales Manager, Local Markets

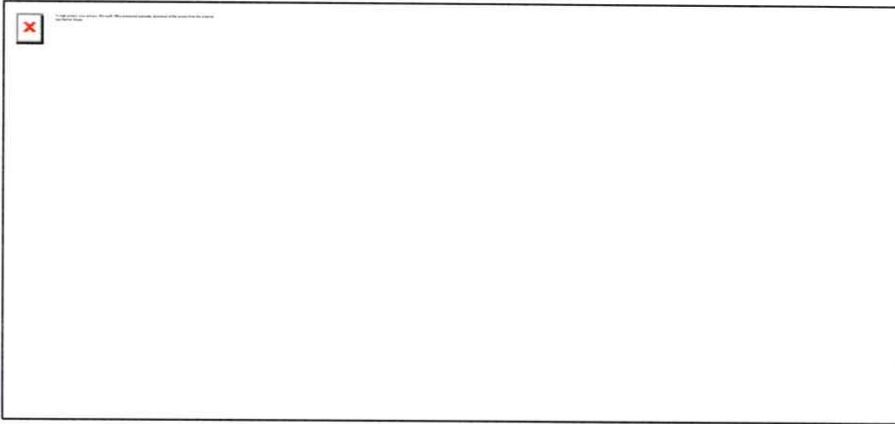

On Tue, Nov 12, 2024 at 10:42 AM Greg Lunsford <glunsford@townofelkton.com> wrote:

Brandon,

I just want to confirm that we will be billed \$12,300 now and the follow-up \$11,000 annual recurring costs will be billed a year from now?

Thanks,

Greg Lunsford

Town Manager

Town of Elkton, VA

540-787-0189

From: Brandon Williams <brandon.williams@flocksafety.com>

Sent: Tuesday, November 12, 2024 9:36 AM

To: Greg Lunsford <glunsford@townofelkton.com>

Subject: Re: Action Required | VA - Elkton PD - Law Enforcement Agreement | Pending Signature

No problem.

The PDF version of the order form is attached.

Let me know if you need anything else from me on my end,

On Tue, Nov 12, 2024 at 9:07 AM Greg Lunsford <glunsford@townofelkton.com> wrote:

Brandon,

Can you please send the document as an attachment that I can print and sign manually and return.

Thank you,

Greg Lunsford

Town Manager

Town of Elkton, VA

540-787-0189

From: Flock Safety <contracts@DocuSign.Flocksafety.com>

Sent: Tuesday, November 12, 2024 9:04 AM

To: Greg Lunsford <glunsford@townofelkton.com>

Subject: Action Required | VA - Elkton PD - Law Enforcement Agreement | Pending Signature

Brandon Williams sent you a document to review and sign.

[REVIEW DOCUMENTS](#)

Brandon Williams

brandon.williams@flocksafety.com

Hi,

The VA - Elkton PD - Law Enforcement Agreement has been routed to you for signature.

Please select the link above to access the agreement and sign in the designated areas.

Thanks!

Powered by

Do Not Share This Email

This email contains a secure link to DocuSign. Please do not share this email, link, or access code with others.

Alternate Signing Method

Visit DocuSign.com, click 'Access Documents', and enter the security code:
7C9852788C034AF1AFC40C32E2EE39657

About DocuSign

Sign documents electronically in just minutes. It's safe, secure, and legally binding. Whether you're in an office, at home, on-the-go -- or even across the globe -- DocuSign provides a professional trusted solution for Digital Transaction Management™.

Questions about the Document?

If you need to modify the document or have questions about the details in the document, please reach out to the sender by emailing them directly.

Stop receiving this email

[Report this email](#) or read more about [Declining to sign](#) and [Managing notifications](#).

If you have trouble signing, visit "[How to Sign a Document](#)" on our [DocuSign Support Center](#), or browse our [DocuSign Community](#) for more information.

[Download the DocuSign App](#)

This message was sent to you by Brandon Williams who is using the DocuSign Electronic Signature Service. If you would rather not receive email from this sender you may contact the sender with your request.

Brandon Williams

Territory Sales Manager, Local Markets



flocksafety.com

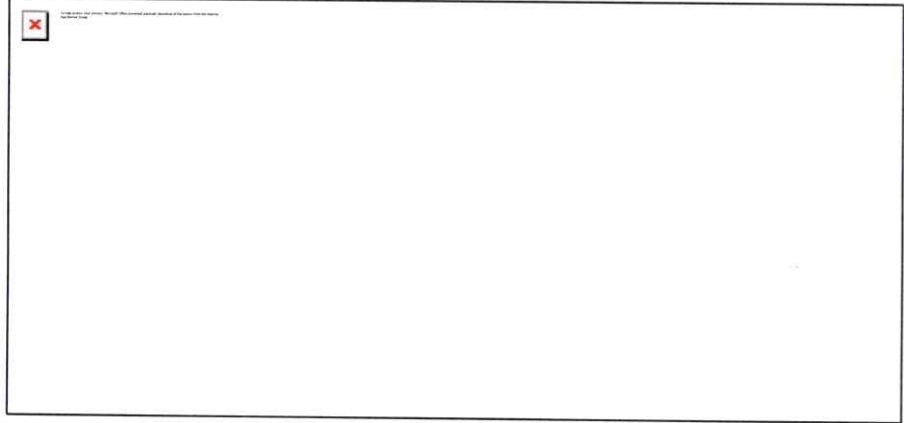
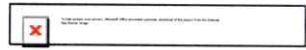

Ryan Insana

From: Greg Lunsford
Sent: Tuesday, November 12, 2024 10:55 AM
To: Donna Curry
Cc: Michael King; Ryan Insana
Subject: FW: Action Required | VA - Elkton PD - Law Enforcement Agreement | Pending Signature
Attachments: VA - Elkton PD - Law Enforcement Agreement - (2).pdf

Donna, just fyi. Will need to make a note that \$11,000 will need to go in the FY 26 PD budget for license plate recognition camera support. The \$12,300 we are spending now is covered by a PD grant. I think the grant covers around \$8K. For the \$11,000 next year (support and maintenance) another grant will be applied for.

Thanks,

Greg Lunsford
Town Manager
Town of Elkton, VA
540-787-0189

From: Brandon Williams <brandon.williams@flocksafety.com>
Sent: Tuesday, November 12, 2024 10:46 AM
To: Greg Lunsford <glunsford@townofelkton.com>
Cc: Michael King <mking@townofelkton.com>; Ryan Insana <rinsana@townofelkton.com>
Subject: Re: Action Required | VA - Elkton PD - Law Enforcement Agreement | Pending Signature

You are correct,

Brandon Williams
Territory Sales Manager, Local Markets



flocksafety.com

flock safety

JOIN OUR LIVE WEBINAR

The Next Frontier in Policing: Introducing Flock Safety's Drones for Rapid Response

NOVEMBER 13TH • 1 PM ET / 10 AM PT

On Tue, Nov 12, 2024 at 10:42 AM Greg Lunsford <glunsford@townofelkton.com> wrote:

Brandon,

I just want to confirm that we will be billed \$12,300 now and the follow-up \$11,000 annual recurring costs will be billed a year from now?

Thanks,

Greg Lunsford

Town Manager

Town of Elkton, VA

540-787-0189

From: Brandon Williams <brandon.williams@flocksafety.com>

Sent: Tuesday, November 12, 2024 9:36 AM

To: Greg Lunsford <glunsford@townofelkton.com>

Subject: Re: Action Required | VA - Elkton PD - Law Enforcement Agreement | Pending Signature

No problem.

The PDF version of the order form is attached.

Let me know if you need anything else from me on my end,

On Tue, Nov 12, 2024 at 9:07 AM Greg Lunsford <glunsford@townofelkton.com> wrote:

Brandon,

Can you please send the document as an attachment that I can print and sign manually and return.

Thank you,

Greg Lunsford

Town Manager

Town of Elkton, VA

540-787-0189

From: Flock Safety <contracts@DocuSign.Flocksafety.com>

Sent: Tuesday, November 12, 2024 9:04 AM

To: Greg Lunsford <glunsford@townofelkton.com>

Subject: Action Required | VA - Elkton PD - Law Enforcement Agreement | Pending Signature

Brandon Williams sent you a document to review and sign.

REVIEW DOCUMENTS

Brandon Williams

brandon.williams@flocksafety.com

Hi,

The VA - Elkton PD - Law Enforcement Agreement has been routed to you for signature.
Please select the link above to access the agreement and sign in the designated areas.

Thanks!

Powered by

Do Not Share This Email

This email contains a secure link to DocuSign. Please do not share this email, link, or access code with others.

Alternate Signing Method

Visit DocuSign.com, click 'Access Documents', and enter the security code:
7C9852788C034AF1AFC40C32E2EE39657

About DocuSign

Sign documents electronically in just minutes. It's safe, secure, and legally binding. Whether you're in an office, at home, on-the-go -- or even across the globe -- DocuSign provides a professional trusted solution for Digital Transaction Management™.

Questions about the Document?

If you need to modify the document or have questions about the details in the document, please reach out to the sender by emailing them directly.

Stop receiving this email

[Report this email](#) or read more about [Declining to sign](#) and [Managing notifications](#).

If you have trouble signing, visit "[How to Sign a Document](#)" on our [DocuSign Support Center](#), or browse our [DocuSign Community](#) for more information.

[Download the DocuSign App](#)

This message was sent to you by Brandon Williams who is using the DocuSign Electronic Signature Service. If you would rather not receive email from this sender you may contact the sender with your request.

Brandon Williams



Territory Sales Manager, Local Markets

[flocksafety.com](#)

flock safety

JOIN OUR LIVE WEBINAR

The Next Frontier in Policing:
**Introducing Flock Safety's
Drones** for Rapid Response

NOVEMBER 13TH • 1 PM ET / 10 AM PT

Ryan Insana

From: Ryan Insana
Sent: Tuesday, November 12, 2024 11:03 AM
To: Greg Lunsford; Donna Curry
Cc: Michael King
Subject: RE: Action Required | VA - Elkton PD - Law Enforcement Agreement | Pending Signature

Hi Greg,

The grant every year is \$12,500. Every year we will reapply for it and be covered for the next. I've discussed with Donna about a new line item getting added for this and then when we get reimbursed from the State Police it will go to pay that line item.

Ryan

From: Greg Lunsford <glunsford@townofelkton.com>
Sent: Tuesday, November 12, 2024 10:55 AM
To: Donna Curry <treasurer@townofelkton.com>
Cc: Michael King <mking@townofelkton.com>; Ryan Insana <rinsana@townofelkton.com>
Subject: FW: Action Required | VA - Elkton PD - Law Enforcement Agreement | Pending Signature

Donna, just fyi. Will need to make a note that \$11,000 will need to go in the FY 26 PD budget for license plate recognition camera support. The \$12,300 we are spending now is covered by a PD grant. I think the grant covers around \$8K. For the \$11,000 next year (support and maintenance) another grant will be applied for.

Thanks,

Greg Lunsford
Town Manager
Town of Elkton, VA
540-787-0189

From: Brandon Williams <brandon.williams@flocksafety.com>
Sent: Tuesday, November 12, 2024 10:46 AM
To: Greg Lunsford <glunsford@townofelkton.com>
Cc: Michael King <mking@townofelkton.com>; Ryan Insana <rinsana@townofelkton.com>
Subject: Re: Action Required | VA - Elkton PD - Law Enforcement Agreement | Pending Signature

You are correct,

Brandon Williams
Territory Sales Manager, Local Markets



flock safety



On Tue, Nov 12, 2024 at 10:42 AM Greg Lunsford <glunsford@townofelkton.com> wrote:

Brandon,

I just want to confirm that we will be billed \$12,300 now and the follow-up \$11,000 annual recurring costs will be billed a year from now?

Thanks,

Greg Lunsford

Town Manager

Town of Elkton, VA

540-787-0189

From: Brandon Williams <brandon.williams@flocksafety.com>

Sent: Tuesday, November 12, 2024 9:36 AM

To: Greg Lunsford <glunsford@townofelkton.com>

Subject: Re: Action Required | VA - Elkton PD - Law Enforcement Agreement | Pending Signature

No problem.

The PDF version of the order form is attached.

Let me know if you need anything else from me on my end,

On Tue, Nov 12, 2024 at 9:07 AM Greg Lunsford <glunsford@townofelkton.com> wrote:

Brandon,

Can you please send the document as an attachment that I can print and sign manually and return.

Thank you,

Greg Lunsford

Town Manager

Town of Elkton, VA

540-787-0189

From: Flock Safety <contracts@DocuSign.Flocksafety.com>

Sent: Tuesday, November 12, 2024 9:04 AM

To: Greg Lunsford <glunsford@townofelkton.com>

Subject: Action Required | VA - Elkton PD - Law Enforcement Agreement | Pending Signature

Brandon Williams sent you a document to review and sign.

[REVIEW DOCUMENTS](#)

Brandon Williams

brandon.williams@flocksafety.com

Hi,

The VA - Elkton PD - Law Enforcement Agreement has been routed to you for signature.
Please select the link above to access the agreement and sign in the designated areas.

Thanks!

Powered by

Do Not Share This Email

This email contains a secure link to DocuSign. Please do not share this email, link, or access code with others.

Alternate Signing Method

Visit DocuSign.com, click 'Access Documents', and enter the security code:
7C9852788C034AF1AFC40C32E2EE39657

About DocuSign

Sign documents electronically in just minutes. It's safe, secure, and legally binding. Whether you're in an office, at home, on-the-go -- or even across the globe -- DocuSign provides a professional trusted solution for Digital Transaction Management™.

Questions about the Document?

If you need to modify the document or have questions about the details in the document, please reach out to the sender by emailing them directly.

Stop receiving this email

[Report this email](#) or read more about [Declining to sign](#) and [Managing notifications](#).

If you have trouble signing, visit "[How to Sign a Document](#)" on our [DocuSign Support Center](#), or browse our [DocuSign Community](#) for more information.

[Download the DocuSign App](#)

This message was sent to you by Brandon Williams who is using the DocuSign Electronic Signature Service. If you would rather not receive email from this sender you may contact the sender with your request.

Brandon Williams

Territory Sales Manager, Local Markets



flocksafety.com

flock safety

JOIN OUR LIVE WEBINAR

The Next Frontier in Policing:
**Introducing Flock Safety's
Drones** for Rapid Response

NOVEMBER 13TH • 1 PM ET / 10 AM PT

Ryan Insana

From: Greg Lunsford
Sent: Tuesday, November 12, 2024 11:32 AM
To: Donna Curry; Ryan Insana
Cc: Michael King
Subject: RE: Action Required | VA - Elkton PD - Law Enforcement Agreement | Pending Signature

OK, great, thanks.

Greg Lunsford
Town Manager
Town of Elkton, VA
540-787-0189

From: Donna Curry <treasurer@townofelkton.com>
Sent: Tuesday, November 12, 2024 11:10 AM
To: Ryan Insana <rinsana@townofelkton.com>; Greg Lunsford <glunsford@townofelkton.com>
Cc: Michael King <mking@townofelkton.com>
Subject: RE: Action Required | VA - Elkton PD - Law Enforcement Agreement | Pending Signature

Greg:

Ryan is correct. We have established a new line in order to track these grant expenditures.

Thanks,
Donna~

From: Ryan Insana <rinsana@townofelkton.com>
Sent: Tuesday, November 12, 2024 11:03 AM
To: Greg Lunsford <glunsford@townofelkton.com>; Donna Curry <treasurer@townofelkton.com>
Cc: Michael King <mking@townofelkton.com>
Subject: RE: Action Required | VA - Elkton PD - Law Enforcement Agreement | Pending Signature

Hi Greg,

The grant every year is \$12,500. Every year we will reapply for it and be covered for the next. I've discussed with Donna about a new line item getting added for this and then when we get reimbursed from the State Police it will go to pay that line item.

Ryan

From: Greg Lunsford <glunsford@townofelkton.com>
Sent: Tuesday, November 12, 2024 10:55 AM
To: Donna Curry <treasurer@townofelkton.com>
Cc: Michael King <mking@townofelkton.com>; Ryan Insana <rinsana@townofelkton.com>
Subject: FW: Action Required | VA - Elkton PD - Law Enforcement Agreement | Pending Signature

Donna, just fyi. Will need to make a note that \$11,000 will need to go in the FY 26 PD budget for license plate recognition camera support. The \$12,300 we are spending now is covered by a PD grant. I think the grant covers around \$8K. For the \$11,000 next year (support and maintenance) another grant will be applied for.

Thanks,

Greg Lunsford
Town Manager
Town of Elkton, VA
540-787-0189

From: Brandon Williams <brandon.williams@flocksafety.com>
Sent: Tuesday, November 12, 2024 10:46 AM
To: Greg Lunsford <glunsford@townofelkton.com>
Cc: Michael King <mking@townofelkton.com>; Ryan Insana <rinsana@townofelkton.com>
Subject: Re: Action Required | VA - Elkton PD - Law Enforcement Agreement | Pending Signature

You are correct,

Brandon Williams



Territory Sales Manager, Local Markets

flocksafety.com

flock safety

JOIN OUR LIVE WEBINAR

The Next Frontier in Policing:
**Introducing Flock Safety's
Drones** for Rapid Response

NOVEMBER 13TH • 1 PM ET / 10 AM PT

On Tue, Nov 12, 2024 at 10:42 AM Greg Lunsford <glunsford@townofelkton.com> wrote:

Brandon,

I just want to confirm that we will be billed \$12,300 now and the follow-up \$11,000 annual recurring costs will be billed a year from now?

Thanks,

Greg Lunsford

Town Manager

Town of Elkton, VA

540-787-0189

From: Brandon Williams <brandon.williams@flocksafety.com>

Sent: Tuesday, November 12, 2024 9:36 AM

To: Greg Lunsford <glunsford@townofelkton.com>

Subject: Re: Action Required | VA - Elkton PD - Law Enforcement Agreement | Pending Signature

No problem.

The PDF version of the order form is attached.

Let me know if you need anything else from me on my end,

On Tue, Nov 12, 2024 at 9:07 AM Greg Lunsford <glunsford@townofelkton.com> wrote:

Brandon,

Can you please send the document as an attachment that I can print and sign manually and return.

Thank you,

Greg Lunsford

Town Manager

Town of Elkton, VA

540-787-0189

From: Flock Safety <contracts@DocuSign.Flocksafety.com>

Sent: Tuesday, November 12, 2024 9:04 AM

To: Greg Lunsford <glunsford@townofelkton.com>

Subject: Action Required | VA - Elkton PD - Law Enforcement Agreement | Pending Signature

Brandon Williams sent you a document to review and sign.

[REVIEW DOCUMENTS](#)

Brandon Williams

brandon.williams@flocksafety.com

Hi,

The VA - Elkton PD - Law Enforcement Agreement has been routed to you for signature.

Please select the link above to access the agreement and sign in the designated areas.

Thanks!

Powered by

Do Not Share This Email

This email contains a secure link to DocuSign. Please do not share this email, link, or access code with others.

Alternate Signing Method

Visit DocuSign.com, click 'Access Documents', and enter the security code:
7C9852788C034AF1AFC40C32E2EE39657

About DocuSign

Sign documents electronically in just minutes. It's safe, secure, and legally binding. Whether you're in an office, at home, on-the-go -- or even across the globe -- DocuSign provides a professional trusted solution for Digital Transaction Management™.

Questions about the Document?

If you need to modify the document or have questions about the details in the document, please reach out to the sender by emailing them directly.

Stop receiving this email

[Report this email](#) or read more about [Declining to sign](#) and [Managing notifications](#).

If you have trouble signing, visit "[How to Sign a Document](#)" on our [DocuSign Support Center](#), or browse our [DocuSign Community](#) for more information.

[Download the DocuSign App](#)

This message was sent to you by Brandon Williams who is using the DocuSign Electronic Signature Service. If you would rather not receive email from this sender you may contact the sender with your request.

--

Brandon Williams



Territory Sales Manager, Local Markets

flocksafety.com

flock safety

JOIN OUR LIVE WEBINAR

The Next Frontier in Policing:
**Introducing Flock Safety's
Drones** for Rapid Response

NOVEMBER 13TH • 1 PM ET / 10 AM PT

Ryan Insana

From: Ryan Insana
Sent: Tuesday, November 26, 2024 10:13 AM
To: Charles Roberts; Alan Johnson; Aaron Meek; Meghan Mugrage; Jeffrey Hylton; Travis Justice; Laron Wharwood
Cc: Michael King
Subject: FW: Flock Safety <> Elkton PD <> Partnership Kick Off
Attachments: Flock Safety Features_Use Cases_V2 (2) (1).pdf; New Sharing Experience PDF .pdf; Role Optimization_Q3 2023.pdf .pdf; VA Example Policy.pdf

Hello all,

Here is how to sign up for the flock training. Go on a day that works for you. All must do this to be able to use this system in the future. Night shift guys, if you sign up for a day that you are off, overtime is authorized. Again this needs to be done prior to using the system. Everyone but Chief and Chuck are users. Chief and Chuck, I signed up for both classes because I have never used this system before. Any questions let me know. Thanks.

Ryan

From: Alyssa Haray <alyssa.haray@flocksafety.com>
Sent: Monday, November 25, 2024 3:46 PM
To: Charmissha Hamlin <charmissha.hamlin@flocksafety.com>
Cc: Ryan Insana <rinsana@townofelkton.com>; Brandon Williams <brandon.williams@flocksafety.com>; Michael King <mking@townofelkton.com>
Subject: Re: Flock Safety <> Elkton PD <> Partnership Kick Off

Good Afternoon All,

Thank you again for your time today! It was great to meet you and learn more about your agency. We look forward to supporting you on your Flock journey.

I've created your Admin accounts for you in the Flock system as well as getting your Sharing Networks going and preferences set! You should have received an email from hello@flocksafety.com with a link that expires in 4 days to set up your password. If you are interested in receiving hotlist alerts via text message, you'll have to add in your cell number by editing your username.

But as we mentioned below I will leave all the resources we discussed earlier:

- Onboarding Deck - if you need to reference anything we covered today
 - [Onboarding deck here](#)
- Accessing FlockOS
 - Website - We suggest using google chromes when using a desktop to laptop <https://search.flocksafety.com/search>
 - Mobile App: - Downloadable in the google play store or apple store, you can gain access to the mobile app. *(Please note you need to set up your alert preferences via desktop for your account)*
- [Training Guide](#) - all of your training materials on the Flock system for the self-paced courses, feel free to share them internally with anyone on the team who will need to be trained.

- Below are our live training webinars, these are hosted weekly to train you and your team on the Flock system

Monday (User Training)	Tuesday (Admin Training)	Wednesday (User Training)	Thursday (Admin Training)
11:00 AM EST / 8:00 AM PST (Registration Link)	12:00 PM EST / 9:00 AM PST (Registration Link)	3:00 PM EST / 12:00 PM PST (Registration Link)	3:00 PM EST / 12:00 PM PST (Registration Link)

- Added Resources -
 - Flock Safety Features
 - Role Creation Guide (attached)
 - Sharing Feature (attached)
 - [ALPR Samples](#) (VA example attached)

Please let me know if you have any questions or need anything at all!

Stay Safe,
Alyssa

On Mon, Nov 25, 2024 at 2:25 PM Charmissha Hamlin <charmissha.hamlin@flocksafety.com> wrote:

Good afternoon,

I appreciate you taking 15-20 min from your busy schedule to speak with your Flock team. As mentioned on our call, once I receive the signed permission letters, your locations will be ready for installation. Your Falcon will be scheduled within the next week or so. Currently, we are experiencing scheduling delays with all Long Range and Condor cameras due to inventory delays. We are working diligently to move scheduling timelines up. I will keep you updated on timelines and check in every 3 weeks (or sooner) with updates.

As discussed, here is the Deployment Tracker [\[link\]](#), It is helpful for seeing where your projects currently stand and when they are scheduled for installation

I am looking forward to working with you and if you have any questions, please do not hesitate to contact me.

Thank you,

Charmissha Hamlin



Project Manager

📞 [404.549.5545](tel:404.549.5545) 🌐 flocksafety.com

flock safety

We're excited to be
ranked **#89** on Deloitte's
Technology Fast 500

GET THE DETAILS

On Mon, Nov 18, 2024 at 12:14 PM Alyssa Haray <alyssa.haray@flocksafety.com> wrote:

Hi Sergeant,

Perfect, thank you! We look forward to meeting. If you need anything before that please let us know.

Best,
Alyssa

On Mon, Nov 18, 2024 at 11:04 AM Ryan Insana <rinsana@townofelkton.com> wrote:

Hi Alyssa,

I'm good for the 25th at 2pm.

Sergeant Ryan M. Insana

Explosive K9 Handler

Town of Elkton Police Department

173 W. Spotswood Ave.

Elkton, VA 22827

Cell: 540-435-2053

Office: 540-298-9441

Fax: 540-298-9499



From: Alyssa Haray <alyssa.haray@flocksafety.com>
Sent: Monday, November 18, 2024 10:25 AM
To: Brandon Williams <brandon.williams@flocksafety.com>
Cc: Michael King <mking@townofelkton.com>; Ryan Insana <rinsana@townofelkton.com>
Subject: Re: Flock Safety <> Elkton PD <> Partnership Kick Off

Hi Chief King & Sergeant Ensana,

Hope you had a great weekend!

Please let us know if the times available to book [here](#) don't work for you, we can send over times if that's easier. We're looking forward to getting your onboarding with Flock started!

Let us know if you have any questions, as Brandon said, we're excited to partner together!

Stay Safe,

Alyssa

On Wed, Nov 13, 2024 at 10:19 AM Brandon Williams <brandon.williams@flocksafety.com> wrote:

Chief King & Sergeant Ensana,

We are extremely excited to get our partnership kicked off.

I wanted to introduce you to your Customer Success Manager Alyssa who will be the main point of contact throughout the onboarding/installation process.

To get things rolling, we'd love to schedule a kick off call to discuss the following...

- Introduce you to our amazing team who will be your go-to partners throughout this process.
- Go over the installation process and timelines to ensure we're all aligned.
- Confirm your goals and objectives with our product to tailor our approach for the best results.

Below is a link to Alyssa's upcoming availability for you to select a time/date that works best for you.

[Book Time Here](#)

Let me know if there are any questions and again we are extremely excited to be partnering together!

--

Brandon Williams

Territory Sales Manager, Local Markets



flocksafety.com

flock safety

JOIN OUR LIVE WEBINAR

The Next Frontier in Policing: Introducing Flock Safety's Drones for Rapid Response

NOVEMBER 13TH • 1 PM ET / 10 AM PT



Alyssa Haray
Customer Success Manager



[470-697-1622](tel:470-697-1622) flocksafety.com

Join our team for a live training session!

[Monday 11am ET / 8am PT – General User Training](#)
[Wednesdays 3pm ET / 12pm PT – General User Training](#)
[Tuesdays 12pm ET / 9am PT – Admin Training](#)
[Thursdays 3pm ET / 12pm PT – Admin Training](#)



Book Time with Me

Ryan Insana

From: Chris at Flock Safety <chris.colwell@flocksafety.com>
Sent: Tuesday, January 27, 2026 1:18 PM
To: Ryan Insana
Subject: Federal Court Upholds Constitutionality of LPR Technology

† Flock Safety

Sergeant Insana,

I'm writing to share an important legal update regarding license plate recognition (LPR) technology following a federal court decision issued today in *Schmidt v. City of Norfolk*, a Fourth Amendment challenge involving the City of Norfolk's use of LPRs.

The court upheld the constitutionality of license plate reader technology as used by the City of Norfolk, dismissing the plaintiffs' claims. This is a significant ruling. As the judge said,

"Despite Plaintiff's counsel's effective advocacy, the Court must conclude that that the limited number of photographs available on a 21-day rolling basis from 75 camera track clusters in Norfolk does not 'track' the whole of a person's movements nor does it provide an 'intimate' window into where citizens drive, park, visit, linger, sleep, or patronize."

Importantly, the court's decision aligns with strong national precedent. It recognizes key distinctions between license plate reader technology and other systems that require a warrant, affirming what courts across the country have consistently found: when used responsibly and lawfully, LPR technology does not constitute continuous surveillance and is constitutional. The court also left open the door to future suits on future facts, so we all must remain diligent to operate LPRs with good policy and within the confines of the law.

For your department, the practical impact is continuity. Law enforcement agencies may continue to use LPRs - and the associated functionality within Flock's system - without a warrant, consistent with existing law and policy. There is no change to service, operations, or partnership as a result of this ruling.

We recognize the gravity of cases like this and remain deeply committed to thoughtful, lawful use of LPR technology. Our focus continues to be supporting

public safety agencies with tools that respect constitutional boundaries, reflect best practices, and stand up to legal scrutiny.

At the same time, we expect the plaintiffs to appeal. And we are prepared to defend this ruling as the process continues and will keep you informed of any material developments. As always, we value your leadership and partnership, and we appreciate the responsibility that comes with deploying these tools in service of your communities.

If you have questions or would like to discuss the decision in more detail, please don't hesitate to reach out.

Respectfully,

Chris Colwell
SVP, Customer Experience

Flock Safety



Flock Safety

1170 Howell Mill Rd NW, Suite 210
Atlanta, Georgia 30318, United States

This email was sent to rinsana@townofelkton.com.

This email is an advertisement. This communication may include content that has been initially drafted or generated using artificial intelligence. All final content and imagery is reviewed and approved by two humans to ensure accuracy and quality.

Copyright © 2026 Flock Safety. All rights reserved.

[Unsubscribe](#) | [Privacy Policy](#)

Ryan Insana

From: Flock Safety Support <support@flocksafety.com>
Sent: Friday, May 23, 2025 7:19 PM
To: heather.phillips@flocksafety.com
Cc: kaci.bemis@flocksafety.com; Ryan Insana
Subject: Re: Flock Safety <> Elkton PD <> Partnership Kick Off

Thank you for looping in Support!

Hi Sgt. Insana,

Our engineers verified that [C#001 W Spotswood Ave @ S Stuart Ave PTZ](#) is working, both live stream and playback. Can you please verify that you can see the same? Please let me know if not, thank you.

Regards,
Charitey
Flock Safety Support

----- Original Message -----

From: Heather Phillips [heather.phillips@flocksafety.com]
Sent: 5/22/2025, 10:41 AM
To: rinsana@townofelkton.com; kaci.bemis@flocksafety.com; support@flocksafety.com
Subject: Re: Flock Safety <> Elkton PD <> Partnership Kick Off

[@Flock Safety Support](#) - Adding in addition - It's wired with power but on the website it says it's failing and the camera is unreachable.

Heather Phillips

Project Manager



 412-512-0563  470-762-4276  flocksafety.com



On Thu, May 22, 2025 at 1:19?PM Heather Phillips <heather.phillips@flocksafety.com> wrote:
Apologies - I assumed it was working! [@Flock Safety Support](#) - can you please assist? This location is now powered however it is not working.

Thank you!

Heather Phillips



Project Manager

 412-512-0563  470-762-4276  flocksafety.com



On Thu, May 22, 2025 at 1:09?PM Ryan Insana <rinsana@townofelkton.com> wrote:

Heather is there a time that it needs to upload, because it says it's failing.

From: Heather Phillips <heather.phillips@flocksafety.com>

Sent: Thursday, May 22, 2025 12:58 PM

To: Ryan Insana <rinsana@townofelkton.com>; Brandon Williams <brandon.williams@flocksafety.com>; Kaci Bemis <kaci.bemis@flocksafety.com>

Subject: Re: Flock Safety <> Elkton PD <> Partnership Kick Off

Thank you so much for the update!

It has been a pleasure to support you throughout this installation process. Although my direct involvement in this project is now complete, please don't hesitate to reach out if there is anything else I can assist you with moving forward.

Thank you!

Heather Phillips



Project Manager



412-512-0563



470-762-4276



flocksafety.com



On Thu, May 22, 2025 at 12:55?PM Ryan Insana <rinsana@townofelkton.com> wrote:

Hello Heather,

The camera is wired and is powered. Thank you.

Sergeant Ryan M. Insana

Explosive K9 Handler

Town of Elkton Police Department

173 W. Spotswood Ave.

Elkton, VA 22827

Cell: 540-435-2053

Office: 540-298-9441

Fax: 540-298-9499



From: Heather Phillips <heather.phillips@flocksafety.com>
Sent: Monday, May 19, 2025 1:12 PM
To: Ryan Insana <rinsana@townofelkton.com>
Subject: Re: Flock Safety <> Elkton PD <> Partnership Kick Off

Good Afternoon,

Wanted to reach out to see if you had any questions regarding AC power hook up? Can you please let me know once it's completed so our team can validate and be sure everything is working properly?

Thank you so much!

Heather Phillips



Project Manager



412-512-0563



470-762-4276



flocksafety.com

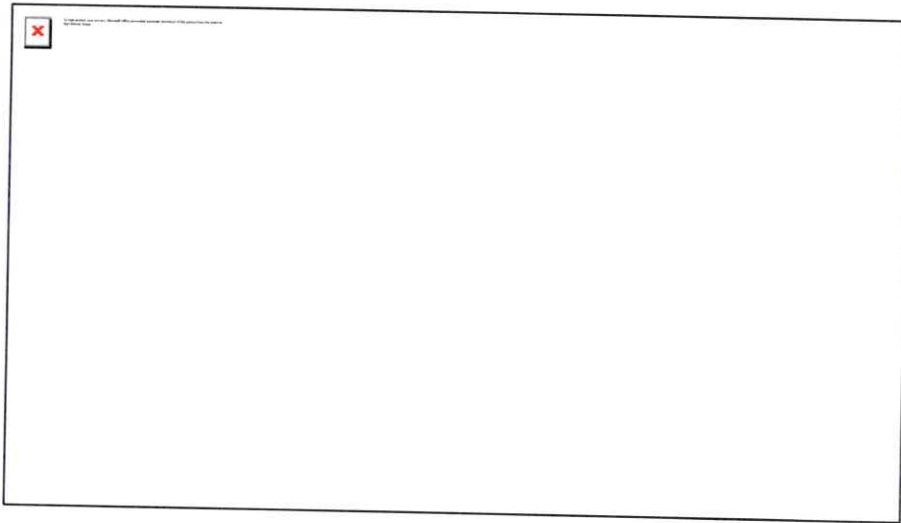

On Mon, May 12, 2025 at 2:14?PM Ryan Insana <rinsana@townofelkton.com> wrote:

Thank you!

From: Heather Phillips <heather.phillips@flocksafety.com>

Sent: Monday, May 12, 2025 1:52 PM

To: Ryan Insana <rinsana@townofelkton.com>; Brandon Williams <brandon.williams@flocksafety.com>

Cc: Michael King <mking@townofelkton.com>

Subject: Re: Flock Safety <> Elkton PD <> Partnership Kick Off

Afternoon,

I apologize for the misunderstanding. Our technicians are not licensed to connect AC power. I've attached the instructions here.

I hope this helps! Please let me know if you need anything else.

Heather Phillips

Project Manager



 412-512-0563  470-762-4276  flocksafety.com

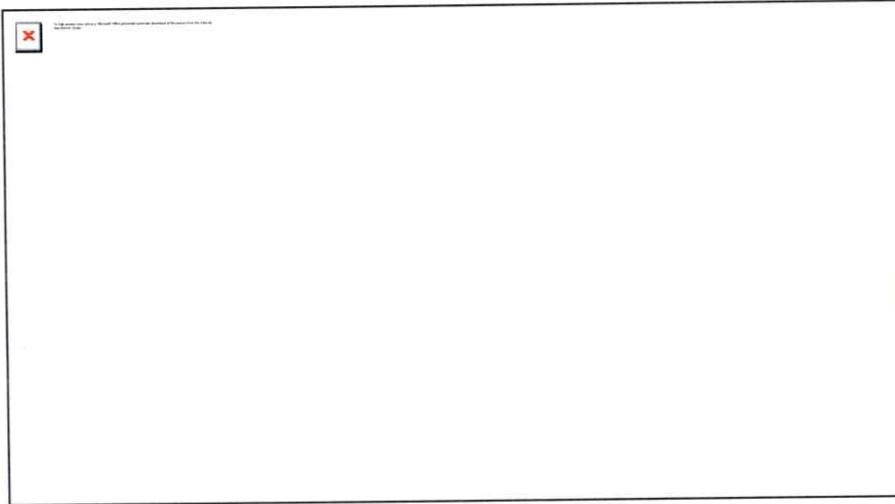

On Mon, May 12, 2025 at 1:48?PM Ryan Insana <rinsana@townofelkton.com> wrote:

Thank you letting us know, we were under the understanding that your company would be hooking up the power. Maybe the Chief and I missed that part in early phone calls. Is there a manual or instructions on how to hook it up, so that we may give it to our public works employees so they do not damage the camera when they hook it up. Thank you.

Sergeant Ryan M. Insana

Explosive K9 Handler

Town of Elkton Police Department

173 W. Spotswood Ave.

Elkton, VA 22827

Cell: 540-435-2053

Office: 540-298-9441

Fax: 540-298-9499



From: Heather Phillips <heather.phillips@flocksafety.com>

Sent: Monday, May 12, 2025 1:28 PM

To: Ryan Insana <rinsana@townofelkton.com>

Cc: Kaci Bemis <kaci.bemis@flocksafety.com>; Michael King <mking@townofelkton.com>; Brandon Williams <brandon.williams@flocksafety.com>

Subject: Re: Flock Safety <> Elkton PD <> Partnership Kick Off

Good Afternoon,

Reaching out to let you know that the install is completed! Please advise once AC power is connected.

Thank you!

Heather Phillips

Project Manager



 412-512-0563  470-762-4276  flocksafety.com

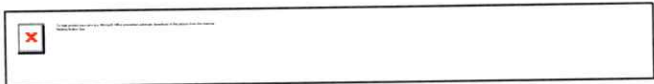
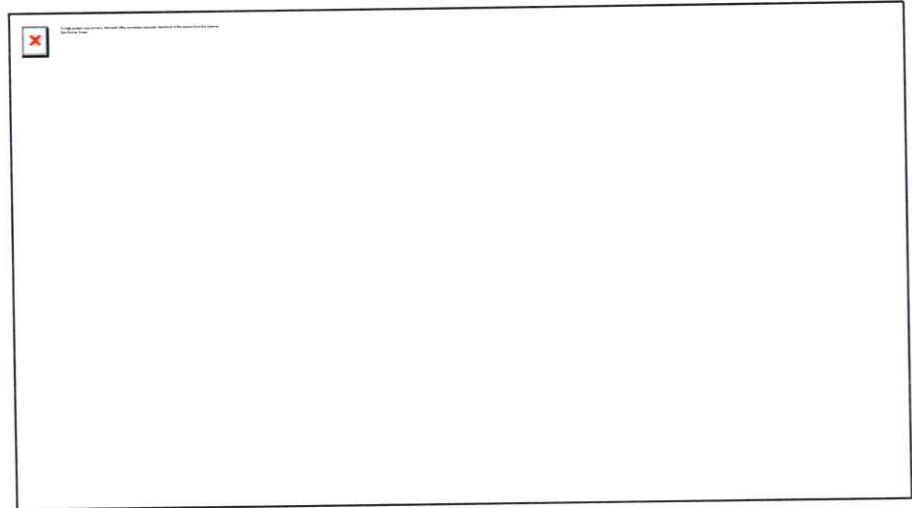

On Thu, May 8, 2025 at 1:34?PM Heather Phillips <heather.phillips@flocksafety.com> wrote:

Good Afternoon,

I apologize for the delay in reaching out. I am following up internally daily on this installation. Currently, Bobby is scheduled to dispatch Monday. I will continue to follow up to ensure success here.



Please reach out in the meantime if you need anything from me.

Thank you,

Heather Phillips

Project Manager



 412-512-0563  470-762-4276  flocksafety.com

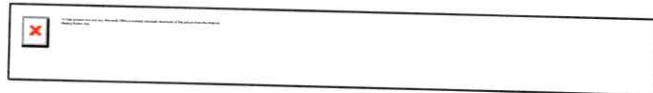
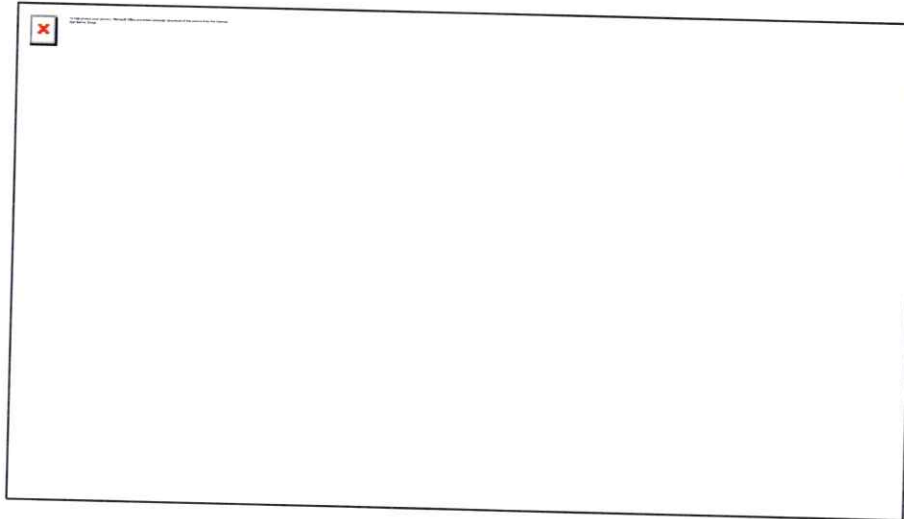

On Wed, Apr 30, 2025 at 12:23?PM Ryan Insana <rinsana@townofelkton.com> wrote:

Thank you for continuing to work on this.

Sergeant Ryan M. Insana

Explosive K9 Handler

Town of Elkton Police Department

173 W. Spotswood Ave.

Elkton, VA 22827

Cell: 540-435-2053

Office: 540-298-9441

Fax: 540-298-9499

On Apr 30, 2025, at 11:30?AM, Heather Phillips <heather.phillips@flocksafety.com> wrote:

Good Morning,

Following up with a quick update. I spoke with our technician Bobby and he confirmed after taking inventory at his warehouse that he has a PTZ allocated for us to install C#001 W Spotswood Ave @ S Stuart Ave. Unfortunately, due to the nationwide shortage, our system had no way of excluding this location from being kicked back. Definitely does not justify the continuous delay. I am working with him to lock in a date as soon as possible.

I will continue to follow up with updates as they are received. Please reach out in the meantime if you need anything.

Heather Phillips

Project Manager



412-512-0563



470-762-4276



flocksafety.com

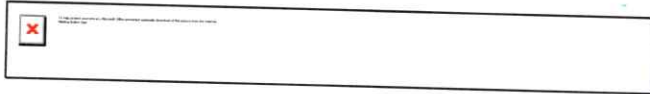
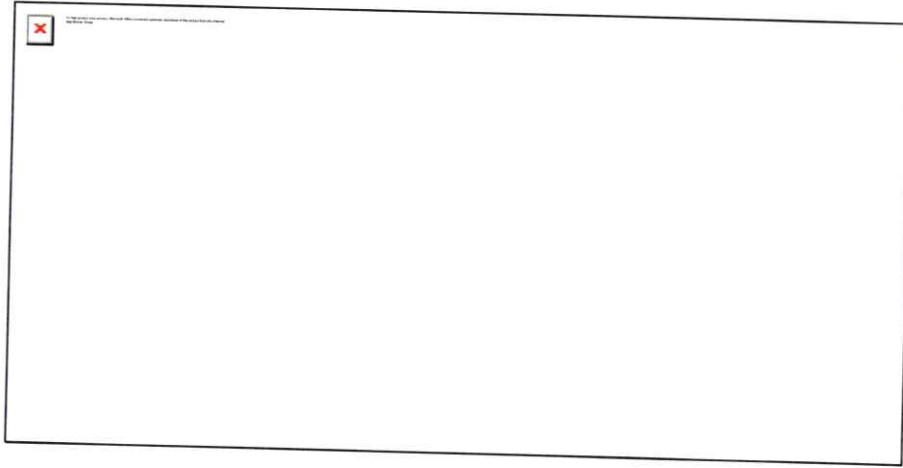

On Fri, Apr 25, 2025 at 2:09?PM Heather Phillips
<heather.phillips@flocksafety.com> wrote:

Good Afternoon,

I wanted to follow up on Kaci's email. I have been assured by our Regional Operations Manager that this installation is marked as a critical priority, and I will continue to monitor the situation closely and share any updates with you as soon as I receive them.

I also followed up with our tech Bobby who was to complete the install originally to inquire (for lack of a better term) "what gives...". I definitely want to learn why the camera allotted for this installation is now not available to produce. Bobby committed that he'd review his inventory and get back with me.

Thank you for your patience, and please do not hesitate to reach out if you have any other questions or concerns.

Thanks,

Heather Phillips



Project Manager



412-512-0563



470-762-4276



flockssafety.com

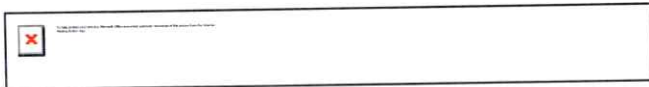
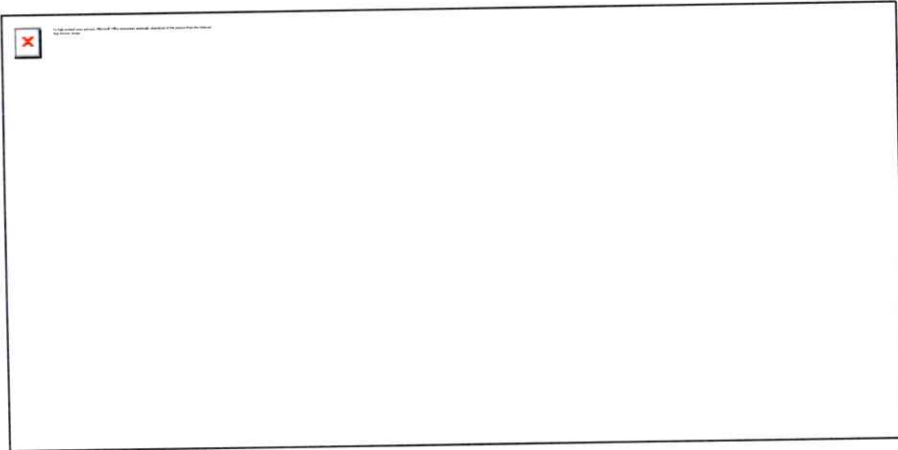

.

On Thu, Apr 24, 2025 at 3:43?PM Kaci Bemis <kaci.bemis@flockssafety.com> wrote:

Hi Sergeant Insana,

My name is Kaci Bemis, and I'm your new Customer Success Manager.

I want to emphasize that Flock Safety values Elkton PD as a partner, regardless of department size.

I understand the frustration caused by the delay in the Condor camera installation, and I sincerely apologize for the inconvenience. To address this, I'm happy to offer a credit to your account to compensate for the wait time. We'll calculate the credit amount based on the total number of days between the initial scheduled date and the actual installation date. Therefore I will need to wait until the camera is in the ground to calculate the monetary value. The credit will then be applied to your next invoice.

I hope this helps and please let me know if you have any questions.

Thank you,

Kaci

On Thu, Apr 24, 2025 at 3:16?PM Ryan Insana <rinsana@townofelkton.com> wrote:

I think less than ideal is an understatement due to the fact that we were to have this camera installed over a month ago and you had one at that time. I understand demand is high but we paid for this 6 months ago and we understood at the time that it was on back order but we didn't think it would take almost 6 months to have it installed. It would have been installed in March if the tech's vehicle hadn't broken down and then it took almost a month to get another tech to come out here again. I understand we are not a large department purchasing 10+ cameras but we are still a customer that uses your products; for example our department located a stolen vehicle out of MD yesterday because of the cameras. Your products are great and have been extremely helpful to our department but I feel customer service is lacking. If you have any thoughts on this please reach out. Thank you.

Sergeant Ryan M. Insana

Explosive K9 Handler

Town of Elkton Police Department

173 W. Spotswood Ave.

Elkton, VA 22827

Cell: 540-435-2053

Office: 540-298-9441

Fax: 540-298-9499

<image001.png>

From: Heather Phillips <heather.phillips@flocksafety.com>
Sent: Thursday, April 24, 2025 12:22 PM
To: Michael King <mking@townofelkton.com>
Cc: Ryan Insana <rinsana@townofelkton.com>; Brandon Williams <brandon.williams@flocksafety.com>; Kaci Bemis <kaci.bemis@flocksafety.com>
Subject: Re: Flock Safety <> Elkton PD <> Partnership Kick Off

Good Afternoon,

I am reaching to inform you that our technician was removed from the schedule yesterday due lack of inventory. I understand this is less than ideal, especially because this project is a critical priority for us, and for you as well.

I am waiting for an update from our Regional Operations Manager regarding the inventory restraints, and I will share any updates as soon as I receive them.

Please reach out in the meantime if you need anything from me.

Thank you,

Heather Phillips

Project Manager

412-512-0563 470-762-4276 flocksafety.com

On Thu, Apr 17, 2025 at 12:50?PM Heather Phillips
<heather.phillips@flocksafety.com> wrote:

Good Afternoon,

I am reaching out to provide a quick update. We have scheduled the installation for location P#001 to take place on **April 23rd**.

Please do not hesitate to reach out if you have any questions or concerns leading up to the installation date.

Thank you,

Heather Phillips

Project Manager

412-512-0563 470-762-4276 flocksafety.com

On Thu, Apr 3, 2025 at 2:33?PM Heather Phillips
<heather.phillips@flocksafety.com> wrote:

Good Afternoon,

I am reaching out to provide a quick update. We have tentatively scheduled the installation for location P#001 to take place on April 24th.

I sincerely apologize for any inconvenience caused by this delay. We appreciate your patience and understanding.

Please do not hesitate to reach out if you have any questions or concerns leading up to the installation date.

Thank you,

Heather Phillips

Project Manager

412-512-0563 470-762-4276 flocksafety.com

On Mon, Mar 31, 2025 at 2:28?PM Heather Phillips
<heather.phillips@flocksafety.com> wrote:

Good Afternoon,

I am writing to inform you that our technician, Bobby, has experienced vehicle issues and is facing delays in completing the installation.

If you need to reach out to him directly, his number is 470-833-8479. We are working toward re-distributing his jobs. I will continue to track and let you know when this is rescheduled.

Thank you,

Heather Phillips

Project Manager

412-512-0563 470-762-4276 flocksafety.com

On Sat, Mar 15, 2025 at 1:23?PM Heather Phillips
<heather.phillips@flocksafety.com> wrote:

Good Afternoon,

Reaching out to let you know that we are tentatively scheduled for install on 3/31.

Please reach out in the meantime if you need anything from me.

Thank you!

Heather Phillips

Project Manager

412-512-0563 470-762-4276 flocksafety.com



thread::ogvPlzGYJK6vBGQYJnEHJg4::

Ryan Insana

From: Kaci Bemis <kaci.bemis@flocksafety.com>
Sent: Wednesday, May 28, 2025 3:39 PM
To: Ryan Insana
Cc: Heather Phillips; Michael King; Brandon Williams
Subject: Re: Flock Safety <> Elkton PD <> Partnership Kick Off

Thank you for the update. I've just submitted a request for a credit of \$1,512, which will be applied to your next invoice once it's approved.

Regarding the Condor camera, I've included some training resources below for your review: [click here](#).

Please don't hesitate to reach out if you have any questions.

Best,
Kaci

On Wed, May 28, 2025 at 2:54 PM Ryan Insana <rinsana@townofelkton.com> wrote:

Hello Kaci,

Yes it is powered on and working, thank you for reaching out.

Sergeant Ryan M. Insana

Explosive K9 Handler

Town of Elkton Police Department

173 W. Spotswood Ave.

Elkton, VA 22827

Cell: 540-435-2053

Office: 540-298-9441

Fax: 540-298-9499



From: Kaci Bemis <kaci.bemis@flocksafety.com>
Sent: Wednesday, May 28, 2025 2:06 PM
To: Heather Phillips <heather.phillips@flocksafety.com>
Cc: Ryan Insana <rinsana@townofelkton.com>; Michael King <mking@townofelkton.com>; Brandon Williams <brandon.williams@flocksafety.com>
Subject: Re: Flock Safety <> Elkton PD <> Partnership Kick Off

Hi there,

Confirming that your Condor has been powered on so I can go ahead and process the credit?

Thanks,

Kaci

On Mon, May 12, 2025 at 1:29 PM Heather Phillips <heather.phillips@flocksafety.com> wrote:

Good Afternoon,

Reaching out to let you know that the install is completed! Please advise once AC power is connected.

Thank you!

Heather Phillips

Project Manager



 [412-512-0563](tel:412-512-0563)  [470-762-4276](tel:470-762-4276)  flocksafety.com

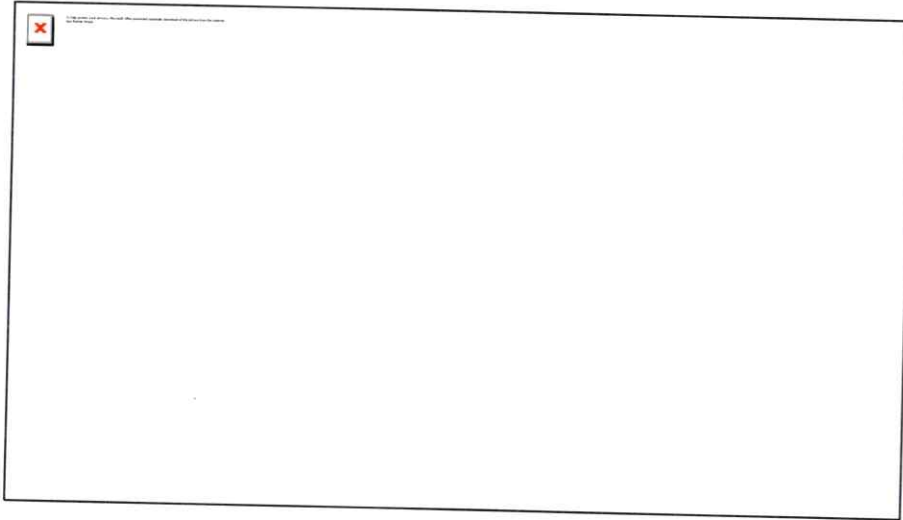

On Thu, May 8, 2025 at 1:34 PM Heather Phillips <heather.phillips@flocksafety.com> wrote:

Good Afternoon,

I apologize for the delay in reaching out. I am following up internally daily on this installation. Currently, Bobby is scheduled to dispatch Monday. I will continue to follow up to ensure success here.

Please reach out in the meantime if you need anything from me.

Thank you,

Heather Phillips



Project Manager



[412-512-0563](tel:412-512-0563)



[470-762-4276](tel:470-762-4276)



flocksafety.com

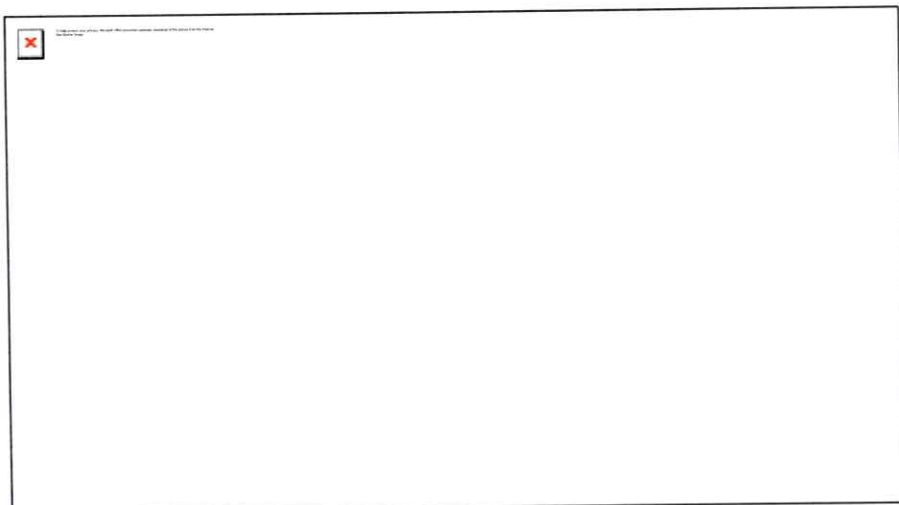

On Wed, Apr 30, 2025 at 12:23 PM Ryan Insana <rinsana@townofelkton.com> wrote:

Thank you for continuing to work on this.

Sergeant Ryan M. Insana

Explosive K9 Handler

Town of Elkton Police Department

173 W. Spotswood Ave.

Elkton, VA 22827

Cell: 540-435-2053

Office: 540-298-9441

Fax: 540-298-9499

On Apr 30, 2025, at 11:30 AM, Heather Phillips <heather.phillips@flocksafety.com> wrote:

Good Morning,

Following up with a quick update. I spoke with our technician Bobby and he confirmed after taking inventory at his warehouse that he has a PTZ allocated for us to install C#001 W Spotswood Ave @ S Stuart Ave. Unfortunately, due to the nationwide shortage, our system had no way of excluding this location from being kicked back. Definitely does not justify the continuous delay. I am working with him to lock in a date as soon as possible.

I will continue to follow up with updates as they are received. Please reach out in the meantime if you need anything.

Heather Phillips

Project Manager



 412-512-0563  470-762-4276  flocksafety.com

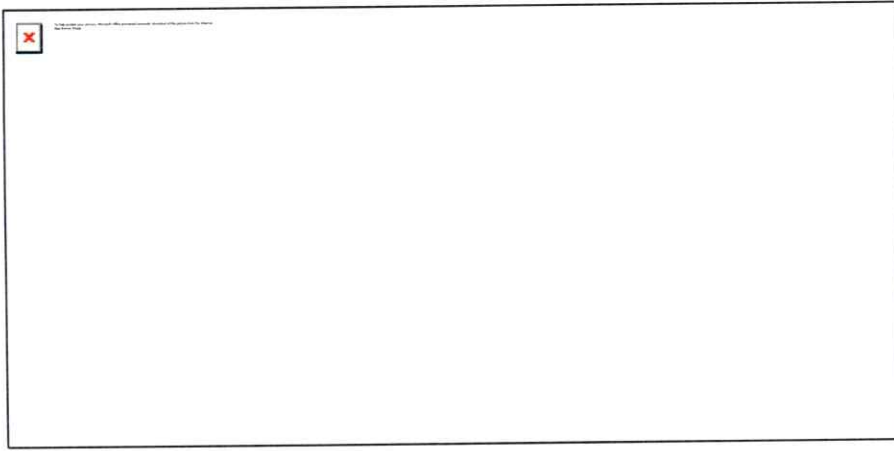

On Fri, Apr 25, 2025 at 2:09 PM Heather Phillips <heather.phillips@flocksafety.com> wrote:

Good Afternoon,

I wanted to follow up on Kaci's email. I have been assured by our Regional Operations Manager that this installation is marked as a critical priority, and I will continue to monitor the situation closely and share any updates with you as soon as I receive them.

I also followed up with our tech Bobby who was to complete the install originally to inquire (for lack of a better term) "what gives...". I definitely want to learn why the camera allotted for this installation is now not available to produce. Bobby committed that he'd review his inventory and get back with me.

Thank you for your patience, and please do not hesitate to reach out if you have any other questions or concerns.

Thanks,

Heather Phillips

Project Manager



412-512-0563



470-762-4276



flocksafety.com

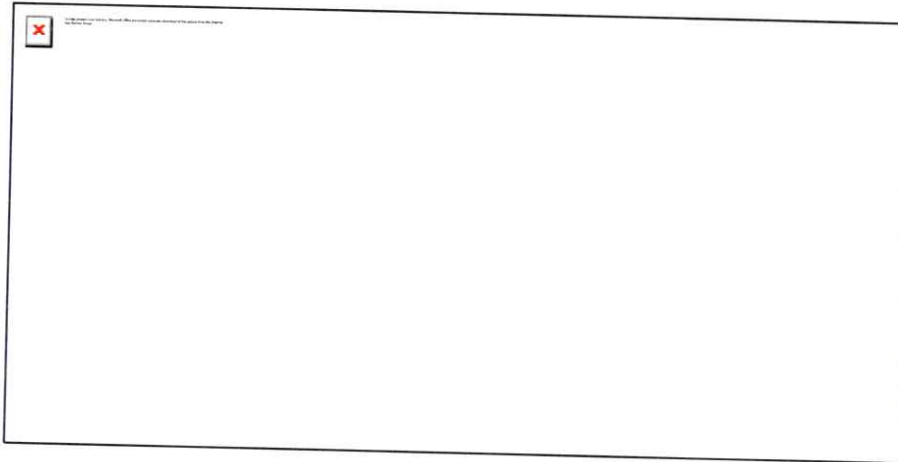

On Thu, Apr 24, 2025 at 3:43 PM Kaci Bemis <kaci.bemis@flocksafety.com> wrote:

Hi Sergeant Insana,

My name is Kaci Bemis, and I'm your new Customer Success Manager.

I want to emphasize that Flock Safety values Elkton PD as a partner, regardless of department size.

I understand the frustration caused by the delay in the Condor camera installation, and I sincerely apologize for the inconvenience. To address this, I'm happy to offer a credit to your account to compensate for the wait time. We'll calculate the credit amount based on the total number of days between the initial scheduled date and the actual installation date. Therefore I will need to wait until the camera is in the ground to calculate the monetary value. The credit will then be applied to your next invoice.

I hope this helps and please let me know if you have any questions.

Thank you,

Kaci

On Thu, Apr 24, 2025 at 3:16 PM Ryan Insana <rinsana@townofelkton.com> wrote:

I think less than ideal is an understatement due to the fact that we were to have this camera installed over a month ago and you had one at that time. I understand demand is high but we paid for this 6 months ago and we understood at the time that it was on back order but we didn't think it would take almost 6 months to have it installed. It would have been installed in March if the tech's vehicle hadn't broken down and then it took almost a month to get another tech to come out here again. I understand we are not a large department purchasing 10+ cameras but we are still a customer that uses your products; for example our department located a stolen vehicle out of MD yesterday because of the cameras. Your products are great and have been extremely helpful to our department but I feel customer service is lacking. If you have any thoughts on this please reach out. Thank you.

Sergeant Ryan M. Insana

Explosive K9 Handler

Town of Elkton Police Department

173 W. Spotswood Ave.

Elkton, VA 22827

Cell: 540-435-2053

Office: 540-298-9441

Fax: 540-298-9499

<image001.png>

From: Heather Phillips <heather.phillips@flocksafety.com>
Sent: Thursday, April 24, 2025 12:22 PM
To: Michael King <mking@townofelkton.com>
Cc: Ryan Insana <rinsana@townofelkton.com>; Brandon Williams <brandon.williams@flocksafety.com>; Kaci Bemis <kaci.bemis@flocksafety.com>
Subject: Re: Flock Safety <> Elkton PD <> Partnership Kick Off

Good Afternoon,

I am reaching to inform you that our technician was removed from the schedule yesterday due lack of inventory. I understand this is less than ideal, especially because this project is a critical priority for us, and for you as well.

I am waiting for an update from our Regional Operations Manager regarding the inventory restraints, and I will share any updates as soon as I receive them.

Please reach out in the meantime if you need anything from me.

Thank you,

Heather Phillips

Project Manager

412-512-0563 470-762-4276 flocksafety.com

On Thu, Apr 17, 2025 at 12:50 PM Heather Phillips
<heather.phillips@flocksafety.com> wrote:

Good Afternoon,

I am reaching out to provide a quick update. We have scheduled the installation for location P#001 to take place on **April 23rd**.

Please do not hesitate to reach out if you have any questions or concerns leading up to the installation date.

Thank you,

Heather Phillips

Project Manager

412-512-0563 470-762-4276 flocksafety.com

On Thu, Apr 3, 2025 at 2:33 PM Heather Phillips
<heather.phillips@flocksafety.com> wrote:

Good Afternoon,

I am reaching out to provide a quick update. We have tentatively scheduled the installation for location P#001 to take place on April 24th.

I sincerely apologize for any inconvenience caused by this delay. We appreciate your patience and understanding.

Please do not hesitate to reach out if you have any questions or concerns leading up to the installation date.

Thank you,

Heather Phillips

Project Manager

412-512-0563 470-762-4276 flocksafety.com

On Mon, Mar 31, 2025 at 2:28 PM Heather Phillips
<heather.phillips@flocksafety.com> wrote:

Good Afternoon,

I am writing to inform you that our technician, Bobby, has experienced vehicle issues and is facing delays in completing the installation.

If you need to reach out to him directly, his number is 470-833-8479. We are working toward re-distributing his jobs. I will continue to track and let you know when this is rescheduled.

Thank you,

Heather Phillips

Project Manager

412-512-0563 470-762-4276 flocksafety.com

On Sat, Mar 15, 2025 at 1:23 PM Heather Phillips
<heather.phillips@flocksafety.com> wrote:

Good Afternoon,

Reaching out to let you know that we are tentatively scheduled for install on 3/31.

Please reach out in the meantime if you need anything from me.

Thank you!

Heather Phillips

Project Manager

412-512-0563 470-762-4276 flocksafety.com

On Wed, Mar 5, 2025 at 12:06 PM Charmissha Hamlin
<charmissha.hamlin@flocksafety.com> wrote:

It was a pleasure speaking with you today, Ryan. As discussed, I am adding you to the email thread for updates moving forward.

Charmissha Hamlin

Project Manager

404.549.5545 flocksafety.com

On Tue, Mar 4, 2025 at 4:37 PM Charmissha Hamlin
<charmissha.hamlin@flocksafety.com> wrote:

Great news, your last location P#001 W Spotswood Ave @ S Stuart Ave PTZ is pending scheduling.

Additionally, I'd like to introduce you to Heather Phillips, who will be your dedicated project manager going forward. Heather will be your primary point of contact throughout the installation process and will ensure a smooth and successful implementation. She will provide regular updates and be available to address any inquiries.

Thank you,

Charmissha Hamlin

Project Manager

404.549.5545 flocksafety.com

On Tue, Jan 21, 2025 at 3:38 PM Charmissha Hamlin
<charmissha.hamlin@flocksafety.com> wrote:

We are tentatively scheduled to install a power module on 2/21. Please let me know if you have any questions.

Thank you,

Charmissha Hamlin

Project Manager

404.549.5545 flocksafety.com

On Mon, Jan 13, 2025 at 1:00 PM Charmissha Hamlin
<charmissha.hamlin@flocksafety.com> wrote:

Good afternoon,

Your location P#002 Spotswood Trail @ Downey Knolls Dr WB is partially installed. I am pending a schedule date to have the power module installed and possibly replace the camera.

Thank you,

Charmissha Hamlin

Project Manager

404.549.5545 flocksafety.com

On Fri, Dec 13, 2024 at 11:42 AM Charmissha Hamlin
<charmissha.hamlin@flocksafety.com> wrote:

Good afternoon,

Your location F#001 340 @ Elkmont Dr NB is installed and currently in our quality control period. Flock will review for 72 hours to ensure that the cameras are meeting and exceeding our functional requirements. Don't be alarmed if within the first 72hrs you notice discoloration, brightness, dim, little blurry. All these issues if they exist should be resolved after that initial 72hr period. In the event something does not meet our expectations during that period we will review with our engineering team and if needed dispatch a technician back to the site to repair or replace the equipment.

Thank you,

Charmissha Hamlin

Project Manager

404.549.5545 flocksafety.com

On Wed, Dec 11, 2024 at 1:33 PM Charmissha Hamlin
<charmissha.hamlin@flocksafety.com> wrote:

Good afternoon,

Your location F#001 340 @ Elkmont Dr NB is rescheduled for 12/13. We have tentatively scheduled your location P#002 Spotswood Trail @ Downey Knolls Dr WB for 1/9/25. Please let me know if you have any questions.

Thank you,

Charmissha Hamlin

Project Manager

404.549.5545 flocksafety.com

On Wed, Dec 4, 2024 at 10:31 AM Charmissha Hamlin
<charmissha.hamlin@flocksafety.com> wrote:

Good morning,

Your location F#001 340 @ Elkmont Dr NB is tentatively scheduled for 12/10. Please let me know if you have any questions.

Thank you,

Charmissha Hamlin

Project Manager

404.549.5545 flocksafety.com

On Tue, Nov 26, 2024 at 11:29 AM Charmissha Hamlin
<charmissha.hamlin@flocksafety.com> wrote:

Good morning,

Thank you, received. Your Falcon location is moved forward for scheduling. As mentioned, the Long Range and Condor cameras are delayed. I will keep you updated on scheduling timelines.

Thank you,

Charmissha Hamlin

Project Manager

404.549.5545 flocksafety.com

On Mon, Nov 25, 2024 at 3:35 PM Michael King
<mking@townofelkton.com> wrote:

Thanks Charmissha,

Mike Lucci has two properties that we'll be installing Flock cameras on so both are included in his attachment. Please let me know if you need anything else from us. I look forward to working with you.

Regards,

Chief Mike King

Elkton Police Department

173 W. Spotswood Ave.

Elkton VA 22827

O: 540-298-9441

F: 540-298-9499

C: 540-560-3503

From: Charmissha Hamlin <charmissha.hamlin@flocksafety.com>

Sent: Monday, November 25, 2024 2:25 PM

To: Alyssa Haray <alyssa.haray@flocksafety.com>

Cc: Ryan Insana <rinsana@townofelkton.com>; Brandon Williams
<brandon.williams@flocksafety.com>; Michael King <mking@townofelkton.com>

Subject: Re: Flock Safety <> Elkton PD <> Partnership Kick Off

Good afternoon,

I appreciate you taking 15-20 min from your busy schedule to speak with your Flock team.

As mentioned on our call, once I receive the signed permission letters, your locations will be ready for installation. Your Falcon will be scheduled within the next week or so. Currently, we are experiencing scheduling delays with all Long Range and Condor cameras due to inventory delays. We are working diligently to move scheduling timelines up. I will keep you updated on timelines and check in every 3 weeks (or sooner) with updates.

As discussed, here is the Deployment Tracker [\[link\]](#) , It is helpful for seeing where your projects currently stand and when they are scheduled for installation

I am looking forward to working with you and if you have any questions, please do not hesitate to contact me.

Thank you,

Charmissha Hamlin
Project Manager

<image002.jpg> <image002.jpg> <image002.jpg>

<image003.jpg>

404.549.5545

<image003.jpg>

flocksafety.com

<image004.jpg>

<image005.jpg>

On Mon, Nov 18, 2024 at 12:14 PM Alyssa Haray
<alyssa.haray@flocksafety.com> wrote:

Hi Sergeant,

Perfect, thank you! We look forward to meeting. If you need anything before that please let us know.

Best,

Alyssa

On Mon, Nov 18, 2024 at 11:04 AM Ryan Insana
<rinsana@townofelkton.com> wrote:

Hi Alyssa,

I'm good for the 25th at 2pm.

Sergeant Ryan M. Insana

Explosive K9 Handler

Town of Elkton Police Department

173 W. Spotswood Ave.

Elkton, VA 22827

Cell: 540-435-2053

Office: 540-298-9441

Fax: 540-298-9499

<image001.png>

From: Alyssa Haray <alyssa.haray@flocksafety.com>
Sent: Monday, November 18, 2024 10:25 AM
To: Brandon Williams <brandon.williams@flocksafety.com>
Cc: Michael King <mking@townofelkton.com>; Ryan Insana <rinsana@townofelkton.com>
Subject: Re: Flock Safety <> Elkton PD <> Partnership Kick Off

Hi Chief King & Sergeant Ensana,

Hope you had a great weekend!

Please let us know if the times available to book [here](#) don't work for you, we can send over times if that's easier. We're looking forward to getting your onboarding with Flock started!

Let us know if you have any questions, as Brandon said, we're excited to partner together!

Stay Safe,

Alyssa

On Wed, Nov 13, 2024 at 10:19 AM Brandon Williams <brandon.williams@flocksafety.com> wrote:

Chief King & Sergeant Ensana,

We are extremely excited to get our partnership kicked off.

I wanted to introduce you to your Customer Success Manager Alyssa who will be the main point of contact throughout the onboarding/installation process.

To get things rolling, we'd love to schedule a kick off call to discuss the following...

- Introduce you to our amazing team who will be your go-to partners throughout this process.
- Go over the installation process and timelines to ensure we're all aligned.
- Confirm your goals and objectives with our product to tailor our approach for the best results.

Below is a link to Alyssa's upcoming availability for you to select a time/date that works best for you.

[Book Time Here](#)

Let me know if there are any questions and again we are extremely excited to be partnering together!

--

Brandon Williams
Territory Sales Manager,
Local Markets

<image002.jpg> <image002.jpg> <image00:

<image003.jpg>

flocksafety.com

<image006.jpg>

<image007.jpg>

<image005.jpg>

<image008.jpg>

--

<image009.jpg>

Alyssa Haray
Customer Success
Manager

<image002.jpg> <image002.jpg>

<image003.jpg>

470-697-1622

<image003.jpg>

flocksafety.com

Join our team for a live training session!

[Monday 11am ET / 8am PT – General User Training](#)

[Wednesdays 3pm ET / 12pm PT – General User Training](#)

[Tuesdays 12pm ET / 9am PT – Admin Training](#)

[Thursdays 3pm ET / 12pm PT – Admin Training](#)

<image010.jpg>

<image011.jpg>

<image005.jpg>

--

<image009.jpg>

Alyssa Haray
Customer Success
Manager

<image002.jpg> <image002.jpg>

<image003.jpg>

[470-697-1622](tel:470-697-1622)

<image003.jpg>

flocksafety.com

Join our team for a live training session!

[Monday 11am ET / 8am PT – General User Training](#)

[Wednesdays 3pm ET / 12pm PT – General User Training](#)

[Tuesdays 12pm ET / 9am PT – Admin Training](#)

[Thursdays 3pm ET / 12pm PT – Admin Training](#)

<image010.jpg>

<image011.jpg>

<image005.jpg>

--

Kaci Bemis



Local Customer Success Manager I



Technical Support: (866) 901-1781



flocksafety.com

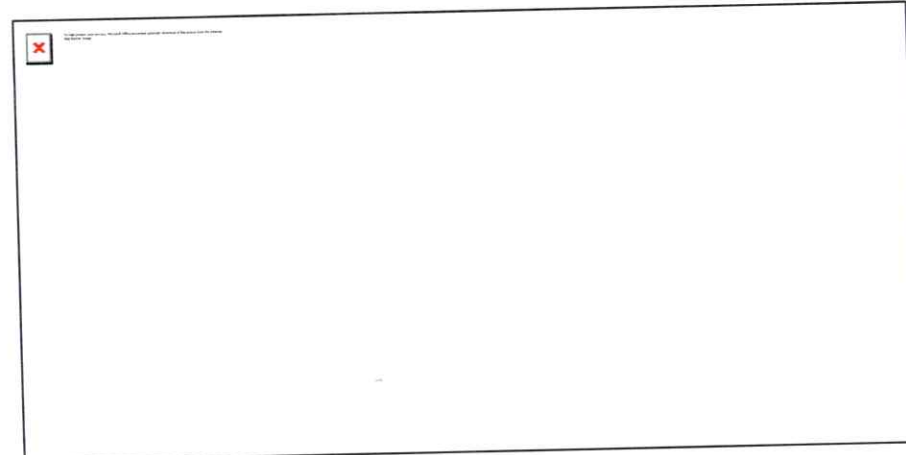

Join our team for a live training session!

[Monday 11am ET / 8am PT – General User Training](#)

[Wednesdays 3pm ET / 12pm PT – General User Training](#)

[Tuesdays 12pm ET / 9am PT – Admin Training](#)

[Thursdays 3pm ET / 12pm PT – Admin Training](#)





--

Kaci Bemis

Local Customer Success Manager I



 Technical Support: (866) 901-1781

 flocksafety.com

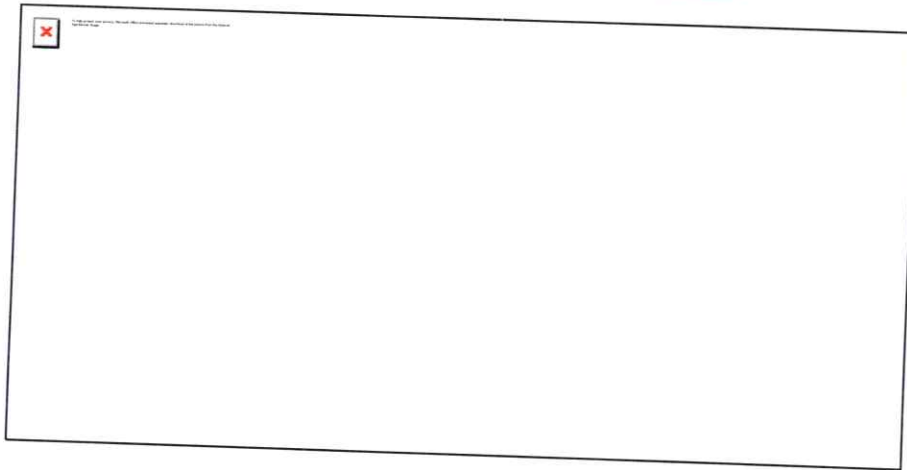

Join our team for a live training session!

[Monday 11am ET / 8am PT – General User Training](#)

[Wednesdays 3pm ET / 12pm PT – General User Training](#)

[Tuesdays 12pm ET / 9am PT – Admin Training](#)

[Thursdays 3pm ET / 12pm PT – Admin Training](#)



--

Kaci Bemis



Local Customer Success Manager I

 [Technical Support: \(866\) 901-1781](tel:(866)901-1781)

 flocksafety.com

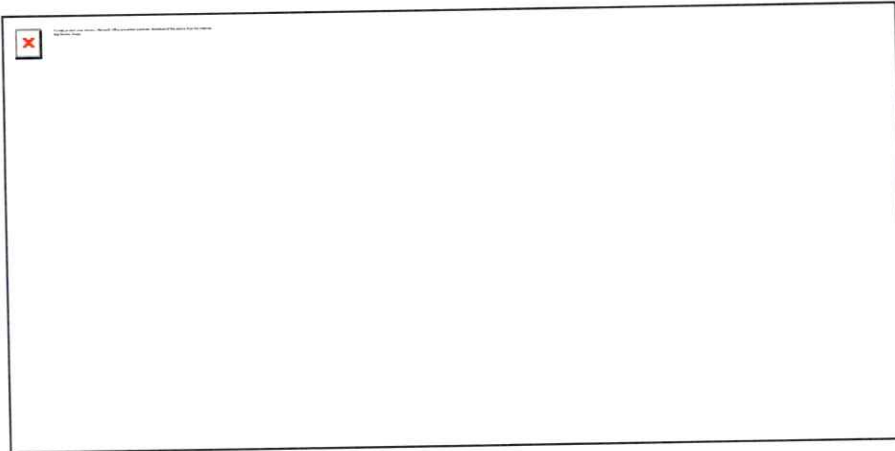

Join our team for a live training session!

[Monday 11am ET / 8am PT – General User Training](#)

[Wednesdays 3pm ET / 12pm PT – General User Training](#)

[Tuesdays 12pm ET / 9am PT – Admin Training](#)

[Thursdays 3pm ET / 12pm PT – Admin Training](#)



Ryan Insana

From: Heather Phillips <heather.phillips@flocksafety.com>
Sent: Thursday, May 22, 2025 1:42 PM
To: Ryan Insana; Kaci Bemis; Flock Safety Support
Subject: Re: Flock Safety <> Elkton PD <> Partnership Kick Off

[@Flock Safety Support](#) - Adding in addition - It's wired with power but on the website it says it's failing and the camera is unreachable.

Heather Phillips

Project Manager



[412-512-0563](tel:412-512-0563) [470-762-4276](tel:470-762-4276) flocksafety.com

[Book Time with Me](#)

On Thu, May 22, 2025 at 1:19 PM Heather Phillips <heather.phillips@flocksafety.com> wrote:
Apologies - I assumed it was working! [@Flock Safety Support](#) - can you please assist? This location is now powered however it is not working.

Thank you!

Heather Phillips

Project Manager



[412-512-0563](tel:412-512-0563) [470-762-4276](tel:470-762-4276) flocksafety.com

[Book Time with Me](#)

On Thu, May 22, 2025 at 1:09 PM Ryan Insana <rinsana@townofelkton.com> wrote:

Heather is there a time that it needs to upload, because it says it's failing.

From: Heather Phillips <heather.phillips@flocksafety.com>

Sent: Thursday, May 22, 2025 12:58 PM

To: Ryan Insana <rinsana@townofelkton.com>; Brandon Williams <brandon.williams@flocksafety.com>; Kaci Bemis <kaci.bemis@flocksafety.com>

Subject: Re: Flock Safety <> Elkton PD <> Partnership Kick Off

Thank you so much for the update!

It has been a pleasure to support you throughout this installation process. Although my direct involvement in this project is now complete, please don't hesitate to reach out if there is anything else I can assist you with moving forward.

Thank you!

Heather Phillips



Project Manager

412-512-0563 470-762-4276 flocksafety.com

Book Time with Me

On Thu, May 22, 2025 at 12:55 PM Ryan Insana <rinsana@townofelkton.com> wrote:

Hello Heather,

The camera is wired and is powered. Thank you.

Sergeant Ryan M. Insana

Explosive K9 Handler

Town of Elkton Police Department

173 W. Spotswood Ave.

Elkton, VA 22827

Cell: 540-435-2053

Office: 540-298-9441

Fax: 540-298-9499



From: Heather Phillips <heather.phillips@flocksafety.com>

Sent: Monday, May 19, 2025 1:12 PM

To: Ryan Insana <rinsana@townofelkton.com>

Subject: Re: Flock Safety <> Elkton PD <> Partnership Kick Off

Good Afternoon,

Wanted to reach out to see if you had any questions regarding AC power hook up? Can you please let me know once it's completed so our team can validate and be sure everything is working properly?

Thank you so much!

Heather Phillips

Project Manager



📞 412-512-0563 📞 470-762-4276 🖱️ flocksafety.com



On Mon, May 12, 2025 at 2:14 PM Ryan Insana <rinsana@townofelkton.com> wrote:

Thank you!

From: Heather Phillips <heather.phillips@flocksafety.com>

Sent: Monday, May 12, 2025 1:52 PM

To: Ryan Insana <rinsana@townofelkton.com>; Brandon Williams <brandon.williams@flocksafety.com>

Cc: Michael King <mking@townofelkton.com>

Subject: Re: Flock Safety <> Elkton PD <> Partnership Kick Off

Afternoon,

I apologize for the misunderstanding. Our technicians are not licensed to connect AC power. I've attached the instructions here.

I hope this helps! Please let me know if you need anything else.

Heather Phillips



Project Manager

[412-512-0563](tel:412-512-0563) [470-762-4276](tel:470-762-4276) flocksafety.com

The banner features a dark background with a green circular logo on the left containing a white stylized bird icon. To the right of the logo, the text "#FoundWithFlock" is displayed in white. At the bottom of the banner, a green horizontal bar contains the text "READ THE ARTICLE" followed by a white arrow pointing to the right.

Book Time with Me

On Mon, May 12, 2025 at 1:48 PM Ryan Insana <rinsana@townofelkton.com> wrote:

Thank you letting us know, we were under the understanding that your company would be hooking up the power. Maybe the Chief and I missed that part in early phone calls. Is there a manual or instructions on how to hook it up, so that we may give it to our public works employees so they do not damage the camera when they hook it up. Thank you.

Sergeant Ryan M. Insana

Explosive K9 Handler

Town of Elkton Police Department

173 W. Spotswood Ave.

Elkton, VA 22827

Cell: 540-435-2053

Office: 540-298-9441

Fax: 540-298-9499



From: Heather Phillips <heather.phillips@flocksafety.com>

Sent: Monday, May 12, 2025 1:28 PM

To: Ryan Insana <rinsana@townofelkton.com>

Cc: Kaci Bemis <kaci.bemis@flocksafety.com>; Michael King <mking@townofelkton.com>; Brandon Williams <brandon.williams@flocksafety.com>

Subject: Re: Flock Safety <> Elkton PD <> Partnership Kick Off

Good Afternoon,

Reaching out to let you know that the install is completed! Please advise once AC power is connected.

Thank you!

Heather Phillips

Project Manager



[412-512-0563](tel:412-512-0563)



[470-762-4276](tel:470-762-4276)



flocksafety.com



On Thu, May 8, 2025 at 1:34 PM Heather Phillips <heather.phillips@flocksafety.com> wrote:

Good Afternoon,

I apologize for the delay in reaching out. I am following up internally daily on this installation. Currently, Bobby is scheduled to dispatch Monday. I will continue to follow up to ensure success here.



Please reach out in the meantime if you need anything from me.

Thank you,

Heather Phillips



Project Manager

 412-512-0563  470-762-4276  flocksafety.com



 **#FoundWithFlock**

READ THE ARTICLE →

 **Book Time with Me**

On Wed, Apr 30, 2025 at 12:23 PM Ryan Insana <rinsana@townofelkton.com> wrote:

Thank you for continuing to work on this.

Sergeant Ryan M. Insana

Explosive K9 Handler

Town of Elkton Police Department

173 W. Spotswood Ave.

Elkton, VA 22827

Cell: 540-435-2053

Office: 540-298-9441

Fax: 540-298-9499

On Apr 30, 2025, at 11:30 AM, Heather Phillips <heather.phillips@flocksafety.com> wrote:

Good Morning,

Following up with a quick update. I spoke with our technician Bobby and he confirmed after taking inventory at his warehouse that he has a PTZ allocated for us to install C#001 W Spotswood Ave @ S Stuart Ave. Unfortunately, due to the nationwide shortage, our system had no way of excluding this location from being kicked back. Definitely does not justify the continuous delay. I am working with him to lock in a date as soon as possible.

I will continue to follow up with updates as they are received. Please reach out in the meantime if you need anything.

Heather Phillips

Project Manager



412-512-0563 470-762-4276 flocksafety.com



On Fri, Apr 25, 2025 at 2:09 PM Heather Phillips <heather.phillips@flocksafety.com> wrote:

Good Afternoon,

I wanted to follow up on Kaci's email. I have been assured by our Regional Operations Manager that this installation is marked as a critical priority, and I will continue to monitor the situation closely and share any updates with you as soon as I receive them.

I also followed up with our tech Bobby who was to complete the install originally to inquire (for lack of a better term) "what gives...". I definitely want to learn why the camera allotted for this installation is now not available to produce. Bobby committed that he'd review his inventory and get back with me.

Thank you for your patience, and please do not hesitate to reach out if you have any other questions or concerns.

Thanks,

Heather Phillips
Project Manager



 412-512-0563  470-762-4276  flocksafety.com

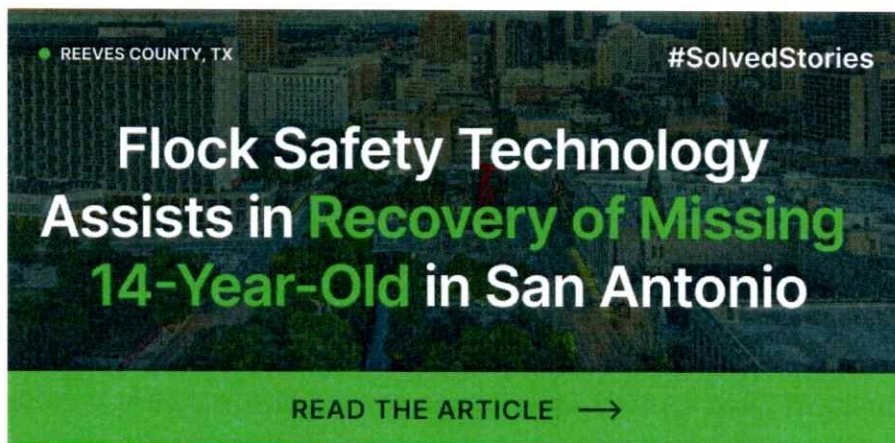

On Thu, Apr 24, 2025 at 3:43 PM Kaci Bemis <kaci.bemis@flocksafety.com> wrote:

Hi Sergeant Insana,

My name is Kaci Bemis, and I'm your new Customer Success Manager.

I want to emphasize that Flock Safety values Elkton PD as a partner, regardless of department size.

I understand the frustration caused by the delay in the Condor camera installation, and I sincerely apologize for the inconvenience. To address this, I'm happy to offer a credit to your account to compensate for the wait time. We'll calculate the credit amount based on the total number of days between the initial scheduled date and the actual installation date. Therefore I will need to wait until the camera is in the ground to calculate the monetary value. The credit will then be applied to your next invoice.

I hope this helps and please let me know if you have any questions.

Thank you,

Kaci

On Thu, Apr 24, 2025 at 3:16 PM Ryan Insana <rinsana@townofelkton.com> wrote:

I think less than ideal is an understatement due to the fact that we were to have this camera installed over a month ago and you had one at that time. I understand demand is high but we paid for this 6 months ago and we understood at the time that it was on back order but we didn't think it would take almost 6 months to have it installed. It would have been installed in March if the tech's vehicle hadn't broken down and then it took almost a month to get another tech to come out here again. I understand we are not a large department purchasing 10+ cameras but we are still a customer that uses your products; for example our department located a stolen vehicle out of MD yesterday because of the cameras. Your products are great and have been extremely helpful to our department but I feel customer service is lacking. If you have any thoughts on this please reach out. Thank you.

Sergeant Ryan M. Insana

Explosive K9 Handler

Town of Elkton Police Department

173 W. Spotswood Ave.

Elkton, VA 22827

Cell: 540-435-2053

Office: 540-298-9441

Fax: 540-298-9499

<image001.png>

From: Heather Phillips <heather.phillips@flocksafety.com>

Sent: Thursday, April 24, 2025 12:22 PM

To: Michael King <mking@townofelkton.com>

Cc: Ryan Insana <rinsana@townofelkton.com>; Brandon Williams <brandon.williams@flocksafety.com>; Kaci Bemis <kaci.bemis@flocksafety.com>

Subject: Re: Flock Safety <> Elkton PD <> Partnership Kick Off

Good Afternoon,

I am reaching to inform you that our technician was removed from the schedule yesterday due lack of inventory. I understand this is less than ideal, especially because this project is a critical priority for us, and for you as well.

I am waiting for an update from our Regional Operations Manager regarding the inventory restraints, and I will share any updates as soon as I receive them.

Please reach out in the meantime if you need anything from me.

Thank you,

Heather Phillips

Project Manager

412-512-0563 470-762-4276 flocksafety.com

On Thu, Apr 17, 2025 at 12:50 PM Heather Phillips
<heather.phillips@flocksafety.com> wrote:

Good Afternoon,

I am reaching out to provide a quick update. We have scheduled the installation for location P#001 to take place on **April 23rd**.

Please do not hesitate to reach out if you have any questions or concerns leading up to the installation date.

Thank you,

Heather Phillips

Project Manager

412-512-0563 470-762-4276 flocksafety.com

On Thu, Apr 3, 2025 at 2:33 PM Heather Phillips
<heather.phillips@flocksafety.com> wrote:

Good Afternoon,

I am reaching out to provide a quick update. We have tentatively scheduled the installation for location P#001 to take place on April 24th.

I sincerely apologize for any inconvenience caused by this delay. We appreciate your patience and understanding.

Please do not hesitate to reach out if you have any questions or concerns leading up to the installation date.

Thank you,

Heather Phillips

Project Manager

412-512-0563 470-762-4276 flocksafety.com

On Mon, Mar 31, 2025 at 2:28 PM Heather Phillips
<heather.phillips@flocksafety.com> wrote:

Good Afternoon,

I am writing to inform you that our technician, Bobby, has experienced vehicle issues and is facing delays in completing the installation.

If you need to reach out to him directly, his number is 470-833-8479. We are working toward re-distributing his jobs. I will continue to track and let you know when this is rescheduled.

Thank you,

Heather Phillips

Project Manager

412-512-0563 470-762-4276 flocksafety.com

On Sat, Mar 15, 2025 at 1:23 PM Heather Phillips
<heather.phillips@flocksafety.com> wrote:

Good Afternoon,

Reaching out to let you know that we are tentatively scheduled for install on 3/31.

Please reach out in the meantime if you need anything from me.

Thank you!

Heather Phillips

Project Manager

412-512-0563 470-762-4276 flocksafety.com

On Wed, Mar 5, 2025 at 12:06 PM Charmissha Hamlin
<charmissha.hamlin@flocksafety.com> wrote:

It was a pleasure speaking with you today, Ryan. As discussed, I am adding you to the email thread for updates moving forward.

Charmissha Hamlin

Project Manager

404.549.5545 flocksafety.com

On Tue, Mar 4, 2025 at 4:37 PM Charmissha Hamlin
<charmissha.hamlin@flocksafety.com> wrote:

Great news, your last location P#001 W Spotswood Ave @ S Stuart Ave PTZ is pending scheduling.

Additionally, I'd like to introduce you to Heather Phillips, who will be your dedicated project manager going forward. Heather will be your primary point of contact throughout the installation process and will ensure a smooth and successful implementation. She will provide regular updates and be available to address any inquiries.

Thank you,

Charmissha Hamlin

Project Manager

404.549.5545 flocksafety.com

On Tue, Jan 21, 2025 at 3:38 PM Charmissha Hamlin
<charmissha.hamlin@flocksafety.com> wrote:

We are tentatively scheduled to install a power module on 2/21. Please let me know if you have any questions.

Thank you,

Charmissha Hamlin

Project Manager

404.549.5545 flocksafety.com

On Mon, Jan 13, 2025 at 1:00 PM Charmissha Hamlin
<charmissha.hamlin@flocksafety.com> wrote:

Good afternoon,

Your location P#002 Spotswood Trail @ Downey Knolls Dr WB is partially installed. I am pending a schedule date to have the power module installed and possibly replace the camera.

Thank you,

Charmissha Hamlin

Project Manager

404.549.5545 flocksafety.com

On Fri, Dec 13, 2024 at 11:42 AM Charmissha Hamlin
<charmissha.hamlin@flocksafety.com> wrote:

Good afternoon,

Your location F#001 340 @ Elkmont Dr NB is installed and currently in our quality control period. Flock will review for 72 hours to ensure that the cameras are meeting and exceeding our functional requirements. Don't be alarmed if within the first 72hrs you notice discoloration, brightness, dim, little blurry. All these issues if they exist should be resolved after that initial 72hr period. In the event something does not meet our expectations during that period we will review with our engineering team and if needed dispatch a technician back to the site to repair or replace the equipment.

Thank you,

Charmissha Hamlin

Project Manager

404.549.5545 flocksafety.com

On Wed, Dec 11, 2024 at 1:33 PM Charmissha Hamlin
<charmissha.hamlin@flocksafety.com> wrote:

Good afternoon,

Your location F#001 340 @ Elkmont Dr NB is rescheduled for 12/13. We have tentatively scheduled your location P#002 Spotswood Trail @ Downey Knolls Dr WB for 1/9/25. Please let me know if you have any questions.

Thank you,

Charmissha Hamlin

Project Manager

404.549.5545 flocksafety.com

On Wed, Dec 4, 2024 at 10:31 AM Charmissha Hamlin
<charmissha.hamlin@flocksafety.com> wrote:

Good morning,

Your location F#001 340 @ Elkmont Dr NB is tentatively scheduled for 12/10. Please let me know if you have any questions.

Thank you,

Charmissha Hamlin

Project Manager

[404.549.5545](tel:404.549.5545) flocksafety.com

On Tue, Nov 26, 2024 at 11:29 AM Charmissha Hamlin
<charmissha.hamlin@flocksafety.com> wrote:

Good morning,

Thank you, received. Your Falcon location is moved forward for scheduling. As mentioned, the Long Range and Condor cameras are delayed. I will keep you updated on scheduling timelines.

Thank you,

Charmissha Hamlin

Project Manager

[404.549.5545](tel:404.549.5545) flocksafety.com

On Mon, Nov 25, 2024 at 3:35 PM Michael King
<mking@townofelkton.com> wrote:

Thanks Charmissha,

Mike Lucci has two properties that we'll be installing Flock cameras on so both are included in his attachment. Please let me know if you need anything else from us. I look forward to working with you.

Regards,

Chief Mike King

Elkton Police Department

173 W. Spotswood Ave.

Elkton VA 22827

O: 540-298-9441

F: 540-298-9499

C: 540-560-3503

From: Charmissha Hamlin <charmissha.hamlin@flocksafety.com>

Sent: Monday, November 25, 2024 2:25 PM

To: Alyssa Haray <alyssa.haray@flocksafety.com>

Cc: Ryan Insana <rinsana@townofelkton.com>; Brandon Williams <brandon.williams@flocksafety.com>; Michael King <mking@townofelkton.com>

Subject: Re: Flock Safety <> Elkton PD <> Partnership Kick Off

Good afternoon,

I appreciate you taking 15-20 min from your busy schedule to speak with your Flock team.

As mentioned on our call, once I receive the signed permission letters, your locations will be ready for installation. Your Falcon will be scheduled within the next week or so. Currently, we are experiencing scheduling delays with all Long Range and Condor cameras due to inventory delays. We are working diligently to move scheduling timelines up. I will keep you updated on timelines and check in every 3 weeks (or sooner) with updates.

As discussed, here is the Deployment Tracker [\[link\]](#) , It is helpful for seeing where your projects currently stand and when they are scheduled for installation

I am looking forward to working with you and if you have any questions, please do not hesitate to contact me.

Thank you,

Charmissha Hamlin
Project Manager

<image002.jpg> <image002.jpg> <image002.jpg>

<image003.jpg>

404.549.5545

<image003.jpg>

flocksafety.com

<image004.jpg>

<image005.jpg>

On Mon, Nov 18, 2024 at 12:14 PM Alyssa Haray
<alyssa.haray@flocksafety.com> wrote:

Hi Sergeant,

Perfect, thank you! We look forward to meeting. If you need anything before that please let us know.

Best,

Alyssa

On Mon, Nov 18, 2024 at 11:04 AM Ryan Insana
<rinsana@townofelkton.com> wrote:

Hi Alyssa,

I'm good for the 25th at 2pm.

Sergeant Ryan M. Insana

Explosive K9 Handler

Town of Elkton Police Department

173 W. Spotswood Ave.

Elkton, VA 22827

Cell: 540-435-2053

Office: 540-298-9441

Fax: 540-298-9499

<image001.png>

From: Alyssa Haray <alyssa.haray@flocksafety.com>
Sent: Monday, November 18, 2024 10:25 AM
To: Brandon Williams <brandon.williams@flocksafety.com>
Cc: Michael King <mking@townofelkton.com>; Ryan Insana <rinsana@townofelkton.com>
Subject: Re: Flock Safety <> Elkton PD <> Partnership Kick Off

Hi Chief King & Sergeant Ensana,

Hope you had a great weekend!

Please let us know if the times available to book [here](#) don't work for you, we can send over times if that's easier. We're looking forward to getting your onboarding with Flock started!

Let us know if you have any questions, as Brandon said, we're excited to partner together!

Stay Safe,

Alyssa

On Wed, Nov 13, 2024 at 10:19 AM Brandon Williams <brandon.williams@flocksafety.com> wrote:

Chief King & Sergeant Ensana,

We are extremely excited to get our partnership kicked off.

I wanted to introduce you to your Customer Success Manager Alyssa who will be the main point of contact throughout the onboarding/installation process.

To get things rolling, we'd love to schedule a kick off call to discuss the following...

- Introduce you to our amazing team who will be your go-to partners throughout this process.
- Go over the installation process and timelines to ensure we're all aligned.
- Confirm your goals and objectives with our product to tailor our approach for the best results.

Below is a link to Alyssa's upcoming availability for you to select a time/date that works best for you.

[Book Time Here](#)

Let me know if there are any questions and again we are extremely excited to be partnering together!

--

Brandon Williams
Territory Sales Manager,
Local Markets

<image002.jpg> <image002.jpg> <image

<image003.jpg>

flocksafety.com

<image006.jpg>

<image007.jpg>

<image005.jpg>

<image008.jpg>

--

<image009.jpg>

Alyssa Haray
Customer Success
Manager

<image002.jpg> <image001.jpg>

<image003.jpg>

470-697-1622

<image003.jpg>

flocksafety.com

Join our team for a live training session!

[Monday 11am ET / 8am PT – General User Training](#)

[Wednesdays 3pm ET / 12pm PT – General User Training](#)

[Tuesdays 12pm ET / 9am PT – Admin Training](#)

[Thursdays 3pm ET / 12pm PT – Admin Training](#)

<image010.jpg>

<image011.jpg>

<image005.jpg>

--

<image009.jpg>

Alyssa Haray
Customer Success
Manager

<image002.jpg> <image001.jpg>

<image003.jpg>

[470-697-1622](tel:470-697-1622)

[flocksafety.com](#)

flocksafety.com

Join our team for a live training session!

[Monday 11am ET / 8am PT – General User Training](#)

[Wednesdays 3pm ET / 12pm PT – General User Training](#)

[Tuesdays 12pm ET / 9am PT – Admin Training](#)

[Thursdays 3pm ET / 12pm PT – Admin Training](#)

<image010.jpg>

<image011.jpg>

<image005.jpg>

--

Kaci Bemis



Local Customer Success Manager I



Technical Support: (866) 901-1781



flocksafety.com



Join our team for a live training session!

[Monday 11am ET / 8am PT – General User Training](#)

[Wednesdays 3pm ET / 12pm PT – General User Training](#)



[Tuesdays 12pm ET / 9am PT – Admin Training](#)

[Thursdays 3pm ET / 12pm PT – Admin Training](#)

Ryan Insana

From: Ryan Insana
Sent: Wednesday, May 21, 2025 11:36 AM
To: Michael King
Cc: Charles Roberts
Subject: Flock Camera

I spoke to Gator today and he is going to look into wiring the last camera.

Sergeant Ryan M. Insana
Explosive K9 Handler
Town of Elkton Police Department
173 W. Spotswood Ave.
Elkton, VA 22827
Cell: 540-435-2053
Office: 540-298-9441
Fax: 540-298-9499



Ryan Insana

From: Flock Safety Support <support@flocksafety.com>
Sent: Tuesday, December 10, 2024 12:23 PM
To: Ryan Insana
Subject: We have rescheduled!



Due to a scheduling conflict, your upcoming Flock Safety appointment for F#001 340 @ Elkmont Dr NB has now been rescheduled. Your new appointment date is 12/13/2024.

We apologize for the inconvenience and thank you for your understanding.

Have questions? Check out the FAQs on our website! - [FAQs](#)
Or you can always email us at support@flocksafety.com and we'll get back to you as soon as possible.



Ryan Insana

From: Flock Safety Daily Digest <digest@flocksafety.com>
Sent: Monday, May 12, 2025 5:02 AM
To: Ryan Insana; Greg Lunsford
Subject: Upcoming Deployment Activity for VA - Elkton PD

flock safety

PLANNING PORTAL

Daily Flock Deployment Status

VA - Elkton PD

Overview

3 Total Locations

66% complete!

0
Planning

0
Permitting

1
Installing

2
LIVE

[View in Planning Portal](#)

Happening This Week

May 12, 2025 - May 18, 2025



P#001 W Spotswood Ave @ S Stuart Av...

Installation

[View happening this week](#)

Happening Next Week

May 19, 2025 - May 25, 2025



You are all caught up for the week!
Check Planning Portal for additional updates in your implementation plan.

Completed yesterday

Sunday, May 11, 2025



Check back later!
Completed work from yesterday will show here.

Scheduling changes



Still on schedule!
Any recent changes to your work schedule will show here.

Ryan Insana

From: Flock Safety Daily Digest <digest@flocksafety.com>
Sent: Monday, April 21, 2025 5:01 AM
To: Ryan Insana; Greg Lunsford
Subject: Upcoming Deployment Activity for VA - Elkton PD



PLANNING PORTAL

Daily Flock Deployment Status

VA - Elkton PD

Overview

3 Total Locations

66% complete!



0
Planning

0
Permitting

1
Installing

2
LIVE

[View in Planning Portal](#)

Happening This Week

April 21, 2025 - April 27, 2025



P#001 W Spotswood Ave @ S Stuart Av...

Installation

[View happening this week](#)

Happening Next Week

April 28, 2025 - May 4, 2025



You are all caught up for the week!
Check Planning Portal for additional updates in your implementation plan.

Completed yesterday

Sunday, April 20, 2025



Check back later!

Completed work from yesterday will show here.

Scheduling changes



Still on schedule!

Any recent changes to your work schedule will show here.

Ryan Insana

From: Flock Safety Daily Digest <digest@flocksafety.com>
Sent: Sunday, April 20, 2025 5:02 AM
To: Greg Lunsford; Ryan Insana
Subject: Upcoming Deployment Activity for VA - Elkton PD



PLANNING PORTAL

Daily Flock Deployment Status

VA - Elkton PD

Overview

3 Total Locations

66% complete!



0
Planning

0
Permitting

1
Installing

2
LIVE

[View in Planning Portal](#)

Happening This Week

April 21, 2025 - April 27, 2025



P#001 W Spotswood Ave @ S Stuart Av...

Installation

[View happening this week](#)

Happening Next Week

April 28, 2025 - May 4, 2025



You are all caught up for the week!

Check Planning Portal for additional updates in your implementation plan.

Completed yesterday

Saturday, April 19, 2025



Check back later!

Completed work from yesterday will show here.

Scheduling changes



Still on schedule!

Any recent changes to your work schedule will show here.

Ryan Insana

From: Flock Safety Daily Digest <digest@flocksafety.com>
Sent: Friday, April 18, 2025 5:00 AM
To: Greg Lunsford; Ryan Insana
Subject: Upcoming Deployment Activity for VA - Elkton PD



PLANNING PORTAL

Daily Flock Deployment Status

VA - Elkton PD

Overview

3 Total Locations

66% complete!



0
Planning

0
Permitting

1
Installing

2
LIVE

[View in Planning Portal](#)

Happening This Week

April 14, 2025 - April 20, 2025



Nothing on the agenda today!
Take a look at the upcoming week.

Happening Next Week

April 21, 2025 - April 27, 2025



View happening next week

Completed yesterday

Thursday, April 17, 2025



Check back later!

Completed work from yesterday will show here.

Scheduling changes



Still on schedule!

Any recent changes to your work schedule will show here.

Ryan Insana

From: Flock Safety Daily Digest <digest@flocksafety.com>
Sent: Friday, February 21, 2025 5:00 AM
To: Ryan Insana; Greg Lunsford
Subject: Upcoming Deployment Activity for VA - Elkton PD



PLANNING PORTAL

Daily Flock Deployment Status

VA - Elkton PD

Overview

5 Total Locations

20% complete!



3
Planning

0
Permitting

1
Installing

1
LIVE

[View in Planning Portal](#)

Happening today

Friday, February 21, 2025



P#002 Spotswood Trail @ Downey KnoL...

Installation

Feb 21, 2025

[View happening today](#)

In the next week

February 22 - 28, 2025



You are all caught up for the week!

Check Planning Portal for additional updates in your implementation plan.

Completed yesterday

Thursday, February 20, 2025



Check back later!

Completed work from yesterday will show here.

Scheduling changes



Still on schedule!

Any recent changes to your work schedule will show here.

Ryan Insana

From: Flock Safety Daily Digest <digest@flocksafety.com>
Sent: Thursday, February 20, 2025 5:00 AM
To: Ryan Insana; Greg Lunsford
Subject: Upcoming Deployment Activity for VA - Elkton PD



PLANNING PORTAL

Daily Flock Deployment Status

VA - Elkton PD

Overview

5 Total Locations

20% complete!



3
Planning

0
Permitting

1
Installing

1
LIVE

[View in Planning Portal](#)

Happening today

Thursday, February 20, 2025



Nothing on the agenda today!

Take a look at the upcoming week.

In the next week

February 21 - 27, 2025



View in the next week

Completed yesterday

Wednesday, February 19, 2025



Check back later!

Completed work from yesterday will show here.

Scheduling changes



Still on schedule!

Any recent changes to your work schedule will show here.

Ryan Insana

From: Flock Safety Daily Digest <digest@flocksafety.com>
Sent: Wednesday, February 19, 2025 5:00 AM
To: Ryan Insana; Greg Lunsford
Subject: Upcoming Deployment Activity for VA - Elkton PD



PLANNING PORTAL

Daily Flock Deployment Status

VA - Elkton PD

Overview

5 Total Locations

20% complete!



3
Planning

0
Permitting

1
Installing

1
LIVE

[View in Planning Portal](#)

Happening today

Wednesday, February 19, 2025



Nothing on the agenda today!

Take a look at the upcoming week.

In the next week

February 20 - 26, 2025



View in the next week

Completed yesterday

Tuesday, February 18, 2025



Check back later!

Completed work from yesterday will show here.

Scheduling changes



Still on schedule!

Any recent changes to your work schedule will show here.

Ryan Insana

From: Flock Safety Daily Digest <digest@flocksafety.com>
Sent: Tuesday, February 18, 2025 5:00 AM
To: Ryan Insana; Greg Lunsford
Subject: Upcoming Deployment Activity for VA - Elkton PD



PLANNING PORTAL

Daily Flock Deployment Status

VA - Elkton PD

Overview

5 Total Locations

20% complete!



3
Planning

0
Permitting

1
Installing

1
LIVE

[View in Planning Portal](#)

Happening today

Tuesday, February 18, 2025



Nothing on the agenda today!

Take a look at the upcoming week.

In the next week

February 19 - 25, 2025



View in the next week

Completed yesterday

Monday, February 17, 2025



Check back later!

Completed work from yesterday will show here.

Scheduling changes



Still on schedule!

Any recent changes to your work schedule will show here.

Ryan Insana

From: Flock Safety Daily Digest <digest@flocksafety.com>
Sent: Monday, February 17, 2025 5:00 AM
To: Ryan Insana; Greg Lunsford
Subject: Upcoming Deployment Activity for VA - Elkton PD



PLANNING PORTAL

Daily Flock Deployment Status

VA - Elkton PD

Overview

5 Total Locations

20% complete!



3
Planning

0
Permitting

1
Installing

1
LIVE

[View in Planning Portal](#)

Happening today

Monday, February 17, 2025



Nothing on the agenda today!

Take a look at the upcoming week.

In the next week

February 18 - 24, 2025



View in the next week

Completed yesterday

Sunday, February 16, 2025



Check back later!

Completed work from yesterday will show here.

Scheduling changes



Still on schedule!

Any recent changes to your work schedule will show here.

Ryan Insana

From: Flock Safety Daily Digest <digest@flocksafety.com>
Sent: Friday, February 14, 2025 5:00 AM
To: Greg Lunsford; Ryan Insana
Subject: Upcoming Deployment Activity for VA - Elkton PD

flock safety

PLANNING PORTAL

Daily Flock Deployment Status

VA - Elkton PD

Overview

5 Total Locations

20% complete!



3
Planning

0
Permitting

1
Installing

1
LIVE

[View in Planning Portal](#)

Happening today

Friday, February 14, 2025



Nothing on the agenda today!

Take a look at the upcoming week.

In the next week

February 15 - 21, 2025



P#002 Spotswood Trail @ Downey Knot...

Installation

Feb 21, 2025

[View in the next week](#)

Completed yesterday

Thursday, February 13, 2025



Check back later!

Completed work from yesterday will show here.

Scheduling changes



Still on schedule!

Any recent changes to your work schedule will show here.

Ryan Insana

From: Flock Safety Daily Digest <digest@flocksafety.com>
Sent: Wednesday, January 8, 2025 5:00 AM
To: Ryan Insana; Greg Lunsford
Subject: Upcoming Deployment Activity for VA - Elkton PD



PLANNING PORTAL

Daily Flock Deployment Status

VA - Elkton PD

Overview

5 Total Locations

20% complete!



3
Planning

0
Permitting

1
Installing

1
LIVE

[View in Planning Portal](#)

Happening today

Wednesday, January 8, 2025



#002 Spotswood Trail @ Downey Knol...

Installation

Jan 8, 2025

[View happening today](#)

In the next week

January 9 - 15, 2025



You are all caught up for the week!
Check Planning Portal for additional updates in your implementation plan.

Completed yesterday

Tuesday, January 7, 2025



Check back later!

Completed work from yesterday will show here.

Scheduling changes



Still on schedule!

Any recent changes to your work schedule will show here.

Ryan Insana

From: Flock Safety Daily Digest <digest@flocksafety.com>
Sent: Tuesday, January 7, 2025 5:00 AM
To: Ryan Insana; Greg Lunsford
Subject: Upcoming Deployment Activity for VA - Elkton PD

flock safety

PLANNING PORTAL

Daily Flock Deployment Status

VA - Elkton PD

Overview

5 Total Locations

20% complete!



3
Planning

0
Permitting

1
Installing

1
LIVE

[View in Planning Portal](#)

Happening today

Tuesday, January 7, 2025



Nothing on the agenda today!

Take a look at the upcoming week.

In the next week

January 8 - 14, 2025



P#002 Spotswood Trail @ Downey Knol...

Installation

Jan 8, 2025

[View in the next week](#)

Completed yesterday

Monday, January 6, 2025



Check back later!

Completed work from yesterday will show here.

Scheduling changes



Still on schedule!

Any recent changes to your work schedule will show here.

Ryan Insana

From: Flock Safety Daily Digest <digest@flocksafety.com>
Sent: Wednesday, December 18, 2024 5:00 AM
To: Greg Lunsford; Ryan Insana
Subject: Upcoming Deployment Activity for VA - Elkton PD



PLANNING PORTAL

Daily Flock Deployment Status

VA - Elkton PD

Overview

5 Total Locations

20% complete!



3
Planning

0
Permitting

1
Installing

1
LIVE

[View in Planning Portal](#)

Happening today

Wednesday, December 18, 2024



Nothing on the agenda today!

Take a look at the upcoming week.

In the next week

December 19 - 25, 2024



You are all caught up for the week!
Check Planning Portal for additional updates in your implementation plan.

Completed yesterday

Tuesday, December 17, 2024



P#002 Spotswood Trail @ Downey Knol...

Site Survey

Dec 17, 2024

[View completed yesterday](#)

Scheduling changes



Still on schedule!

Any recent changes to your work schedule will show here.

Ryan Insana

From: Flock Safety Daily Digest <digest@flocksafety.com>
Sent: Tuesday, December 17, 2024 5:00 AM
To: Ryan Insana; Greg Lunsford
Subject: Upcoming Deployment Activity for VA - Elkton PD



PLANNING PORTAL

Daily Flock Deployment Status

VA - Elkton PD

Overview

5 Total Locations

20% complete!



3
Planning

0
Permitting

1
Installing

1
LIVE

[View in Planning Portal](#)

Happening today

Tuesday, December 17, 2024



P#002 Spotswood Trail @ Downey Kno...

Site Survey

Dec 17, 2024

[View happening today](#)

In the next week

December 18 - 24, 2024



You are all caught up for the week!
Check Planning Portal for additional updates in your implementation plan.

Completed yesterday

Monday, December 16, 2024



Check back later!

Completed work from yesterday will show here.

Scheduling changes



Still on schedule!

Any recent changes to your work schedule will show here.

Ryan Insana

From: Flock Safety Daily Digest <digest@flocksafety.com>
Sent: Sunday, December 15, 2024 5:00 AM
To: Greg Lunsford; Ryan Insana
Subject: Upcoming Deployment Activity for VA - Elkton PD



PLANNING PORTAL

Daily Flock Deployment Status

VA - Elkton PD

Overview

5 Total Locations

20% complete!



3
Planning

0
Permitting

1
Installing

1
LIVE

[View in Planning Portal](#)

Happening today

Sunday, December 15, 2024



Nothing on the agenda today!

Take a look at the upcoming week.

In the next week

December 16 - 22, 2024



View in the next week

Completed yesterday

Saturday, December 14, 2024



Check back later!

Completed work from yesterday will show here.

Scheduling changes



Still on schedule!

Any recent changes to your work schedule will show here.

Ryan Insana

From: Flock Safety Daily Digest <digest@flocksafety.com>
Sent: Friday, December 13, 2024 5:01 AM
To: Greg Lunsford; Ryan Insana
Subject: Upcoming Deployment Activity for VA - Elkton PD



PLANNING PORTAL

Daily Flock Deployment Status

VA - Elkton PD

Overview

5 Total Locations

20% complete!



3
Planning

0
Permitting

1
Installing

1
LIVE

[View in Planning Portal](#)

Happening today

Friday, December 13, 2024



Nothing on the agenda today!
Take a look at the upcoming week.

In the next week

December 14 - 20, 2024



P#002 Spotswood Trail @ Downey Knol...

Site Survey

Dec 17, 2024

[View in the next week](#)

Completed yesterday

Thursday, December 12, 2024



F#001 340 @ Elkmont Dr NB

Installation

Dec 12, 2024

[View completed yesterday](#)

Scheduling changes



Still on schedule!

Any recent changes to your work schedule will show here.

Ryan Insana

From: Flock Safety Daily Digest <digest@flocksafety.com>
Sent: Thursday, December 12, 2024 5:00 AM
To: Ryan Insana; Greg Lunsford
Subject: Upcoming Deployment Activity for VA - Elkton PD



PLANNING PORTAL

Daily Flock Deployment Status

VA - Elkton PD

Overview

5 Total Locations

0% complete!



3
Planning

0
Permitting

2
Installing

0
LIVE

[View in Planning Portal](#)

Happening today

Thursday, December 12, 2024



Nothing on the agenda today!

Take a look at the upcoming week.

In the next week

December 13 - 19, 2024



F#001 340 @ Elkmont Dr NB

Installation

Dec 13, 2024



P#002 Spotswood Trail @ Downey Kno...

Site Survey

Dec 17, 2024

View in the next week

Completed yesterday

Wednesday, December 11, 2024



Check back later!

Completed work from yesterday will show here.

Scheduling changes



Still on schedule!

Any recent changes to your work schedule will show here.

Ryan Insana

From: Flock Safety Daily Digest <digest@flocksafety.com>
Sent: Wednesday, December 11, 2024 5:00 AM
To: Ryan Insana; Greg Lunsford
Subject: Upcoming Deployment Activity for VA - Elkton PD



PLANNING PORTAL

Daily Flock Deployment Status

VA - Elkton PD

Overview

5 Total Locations

0% complete!



3
Planning

0
Permitting

2
Installing

0
LIVE

[View in Planning Portal](#)

Happening today

Wednesday, December 11, 2024



Nothing on the agenda today!

Take a look at the upcoming week.

In the next week

December 12 - 18, 2024



F#001 340 @ Elkmont Dr NB

Installation

Dec 13, 2024

[View in the next week](#)

Completed yesterday

Tuesday, December 10, 2024



Check back later!

Completed work from yesterday will show here.

Scheduling changes



F#001 340 @ Elkmont Dr NB

Installation

~~Dec 10, 2024~~

Dec 13, 2024

Ryan Insana

From: Flock Safety Daily Digest <digest@flocksafety.com>
Sent: Tuesday, December 10, 2024 5:00 AM
To: Greg Lunsford; Ryan Insana
Subject: Upcoming Deployment Activity for VA - Elkton PD



PLANNING PORTAL

Daily Flock Deployment Status

VA - Elkton PD

Overview

5 Total Locations

0% complete!

3
Planning

0
Permitting

2
Installing

0
LIVE

[View in Planning Portal](#)

Happening today

Tuesday, December 10, 2024



F#001 340 @ Elkmont Dr NB

Installation

Dec 10, 2024

[View happening today](#)

In the next week

December 11 - 17, 2024



You are all caught up for the week!
Check Planning Portal for additional updates in your implementation plan.

Completed yesterday

Monday, December 9, 2024



Check back later!

Completed work from yesterday will show here.

Scheduling changes



Still on schedule!

Any recent changes to your work schedule will show here.

Ryan Insana

From: Flock Safety Daily Digest <digest@flocksafety.com>
Sent: Monday, December 9, 2024 5:00 AM
To: Ryan Insana; Greg Lunsford
Subject: Upcoming Deployment Activity for VA - Elkton PD



PLANNING PORTAL

Daily Flock Deployment Status

VA - Elkton PD

Overview

5 Total Locations

0% complete!

4
Planning

0
Permitting

1
Installing

0
LIVE

[View in Planning Portal](#)

Happening today

Monday, December 9, 2024



Nothing on the agenda today!

Take a look at the upcoming week.

In the next week

December 10 - 16, 2024



View in the next week

Completed yesterday

Sunday, December 8, 2024



Check back later!

Completed work from yesterday will show here.

Scheduling changes



Still on schedule!

Any recent changes to your work schedule will show here.

Ryan Insana

From: Flock Safety Daily Digest <digest@flocksafety.com>
Sent: Sunday, December 8, 2024 5:00 AM
To: Ryan Insana; Greg Lunsford
Subject: Upcoming Deployment Activity for VA - Elkton PD



PLANNING PORTAL

Daily Flock Deployment Status

VA - Elkton PD

Overview

5 Total Locations

0% complete!



4
Planning

0
Permitting

1
Installing

0
LIVE

[View in Planning Portal](#)

Happening today

Sunday, December 8, 2024



Nothing on the agenda today!

Take a look at the upcoming week.

In the next week

December 9 - 15, 2024



F#001 340 @ Elkmont Dr NB

Installation

Dec 10, 2024

[View in the next week](#)

Completed yesterday

Saturday, December 7, 2024



Check back later!

Completed work from yesterday will show here.

Scheduling changes



Still on schedule!

Any recent changes to your work schedule will show here.

Ryan Insana

From: Flock Safety Daily Digest <digest@flocksafety.com>
Sent: Friday, December 6, 2024 5:00 AM
To: Greg Lunsford; Ryan Insana
Subject: Upcoming Deployment Activity for VA - Elkton PD



PLANNING PORTAL

Daily Flock Deployment Status

VA - Elkton PD

Overview

5 Total Locations

0% complete!



[View in Planning Portal](#)

Happening today

Friday, December 6, 2024



Nothing on the agenda today!

Take a look at the upcoming week.

In the next week

December 7 - 13, 2024



View in the next week

Completed yesterday

Thursday, December 5, 2024



Check back later!

Completed work from yesterday will show here.

Scheduling changes



Still on schedule!

Any recent changes to your work schedule will show here.

flock safety

PLANNING PORTAL

Daily Flock Deployment Status

VA - Elkton PD

Overview

5 Total Locations

0% complete!



4
Planning

0
Permitting

1
Installing

0
LIVE

[View in Planning Portal](#)

Happening today

Thursday, December 5, 2024



Nothing on the agenda today!

Take a look at the upcoming week.

In the next week

December 6 - 12, 2024



F#001 340 @ Elkmont Dr NB

Installation

Dec 10, 2024

[View in the next week](#)

Ryan Insana

From: Ryan Insana
Sent: Thursday, December 5, 2024 11:21 AM
To: Charles Roberts
Subject: Fwd: Upcoming Deployment Activity for VA - Elkton PD

Just fyi.... It looks like we will get our first camera installed next week on the 10 th.

Sergeant Ryan M. Insana
Explosive K9 Handler
Town of Elkton Police Department
173 W. Spotswood Ave.
Elkton, VA 22827
Cell: 540-435-2053
Office: 540-298-9441
Fax: 540-298-9499

Begin forwarded message:

From: Ryan Insana <rinsana@townofelkton.com>
Date: December 5, 2024 at 9:56:20 AM EST
To: Michael King <mking@townofelkton.com>
Subject: **Fwd: Upcoming Deployment Activity for VA - Elkton PD**

Looks like they will be putting in the camera at the electrical business on the 10th.

Sergeant Ryan M. Insana
Explosive K9 Handler
Town of Elkton Police Department
173 W. Spotswood Ave.
Elkton, VA 22827
Cell: 540-435-2053
Office: 540-298-9441
Fax: 540-298-9499

Begin forwarded message:

From: Flock Safety Daily Digest <digest@flocksafety.com>
Date: December 5, 2024 at 5:00:41 AM EST
To: Greg Lunsford <glunsford@townofelkton.com>, Ryan Insana <rinsana@townofelkton.com>
Subject: **Upcoming Deployment Activity for VA - Elkton PD**

Ryan Insana

From: Flock Safety Daily Digest <digest@flocksafety.com>
Sent: Thursday, December 5, 2024 5:00 AM
To: Greg Lunsford; Ryan Insana
Subject: Upcoming Deployment Activity for VA - Elkton PD



PLANNING PORTAL

Daily Flock Deployment Status

VA - Elkton PD

Overview

5 Total Locations

0% complete!



4
Planning

0
Permitting

1
Installing

0
LIVE

[View in Planning Portal](#)

Happening today

Thursday, December 5, 2024



Nothing on the agenda today!

Take a look at the upcoming week.

In the next week

December 6 - 12, 2024



F#001 340 @ Elkmont Dr NB

Installation

Dec 10, 2024

View in the next week

Completed yesterday

Wednesday, December 4, 2024



Check back later!

Completed work from yesterday will show here.

Scheduling changes



Still on schedule!

Any recent changes to your work schedule will show here.

Completed yesterday

Wednesday, December 4, 20



Check back later!

Completed work from yesterday will show here.

Scheduling changes



Still on schedule!

Any recent changes to your work schedule will show here.

Ryan Insana

From: Ryan Insana
Sent: Wednesday, December 11, 2024 2:15 PM
To: Donna Curry
Subject: FW: Elkton Police Department HEAT GRANT

Just for your records. Email chain between us and VSP about repayment of the grant for the cameras.

Ryan

From: Lazear, Peter (VSP) <peter.lazear@vsp.virginia.gov>
Sent: Wednesday, December 11, 2024 2:04 PM
To: Ryan Insana <rinsana@townofelkton.com>
Subject: Re: Elkton Police Department HEAT GRANT

Thank you for the prompt reply and for sending your supporting documentation. I have submitted a payment request to my Property & Finance Division in the amount of \$12,300 to your agency. Please allow several weeks for the payment to be processed.

I hope the Flock equipment serves your community well!

Sincerely,
Peter

First Sergeant Peter W. Lazear

Statewide Program Coordinator

President - International Association of Auto Theft Investigators - Southeast Chapter

Virginia Department of State Police

Help Eliminate Auto Theft

Insurance Fraud Program

7700 Midlothian Turnpike

N. Chesterfield, VA 23235-5226

Cell: (804) 221-0997

www.HEATreward.com (-> heatreward.com)

www.StampOutFraud.com

The information in this email and any attachments may be confidential and privileged. Access to this email by anyone other than the intended addressee is unauthorized. If you are not the intended recipient (or the employee or agent responsible for delivering this information to the intended recipient) please notify the sender by reply email and immediately delete this email and any copies from your computer and/or storage system. The sender does not authorize the use, distribution, disclosure or reproduction of this email (or any part of its contents) by anyone other than the intended recipient(s). No representation is made that this

email and any attachments are free of viruses. Virus scanning is recommended and is the responsibility of the recipient.

From: Ryan Insana <rinsana@townofelkton.com>
Sent: Wednesday, December 11, 2024 1:21 PM
To: Lazear, Peter (VSP) <peter.lazear@vsp.virginia.gov>
Subject: Re: Elkton Police Department HEAT GRANT

Hello Sir,

Yes I am ok with the extra money going to another department. Thank you.

Sergeant Ryan M. Insana
Explosive K9 Handler
Town of Elkton Police Department
173 W. Spotswood Ave.
Elkton, VA 22827
Cell: 540-435-2053
Office: 540-298-9441
Fax: 540-298-9499

On Dec 11, 2024, at 12:09 PM, Lazear, Peter (VSP) <peter.lazear@vsp.virginia.gov> wrote:

Good Afternoon,

This receipt is, indeed, all I need. However, before I proceed, I just wanted to confirm because your application requested \$12,500 but your receipt is for \$12,300. Are you okay with me re-allocating your remaining \$200 to another law enforcement agency?

Thanks in advance,
Peter

First Sergeant Peter W. Lazear

Statewide Program Coordinator

President - International Association of Auto Theft Investigators - Southeast Chapter

Virginia Department of State Police

Help Eliminate Auto Theft

Insurance Fraud Program

7700 Midlothian Turnpike

N. Chesterfield, VA 23235-5226

Cell: (804) 221-0997

www.HEATreward.com (-> heatreward.com)

www.StampOutFraud.com

The information in this email and any attachments may be confidential and privileged. Access to this email by anyone other than the intended addressee is unauthorized. If you are not the intended recipient (or the employee or agent responsible for delivering this information to the intended recipient) please notify the sender by reply email and immediately delete this email and any copies from your computer and/or storage system. The sender does not authorize the use, distribution, disclosure or reproduction of this email (or any part of its contents) by anyone other than the intended recipient(s). No representation is made that this email and any attachments are free of viruses. Virus scanning is recommended and is the responsibility of the recipient.

From: Ryan Insana <rinsana@townofelkton.com>
Sent: Monday, December 9, 2024 10:24 AM
To: Lazear, Peter (VSP) <peter.lazear@vsp.virginia.gov>
Subject: Elkton Police Department HEAT GRANT

Good Morning First Sergeant Lazear,

Sir, here is our invoice from FLOCK and the check that we sent them for payment from the Town. According to your email that was all that you needed on our end. If you need any additional information please reach out and I will get it to you as soon as possible. Thank you for your time on this.

Respectfully,

Sergeant Ryan M. Insana
Explosive K9 Handler
Town of Elkton Police Department
173 W. Spotswood Ave.
Elkton, VA 22827
Cell: 540-435-2053
Office: 540-298-9441
Fax: 540-298-9499

<image001.png>

From: copier@townofelkton.com <copier@townofelkton.com>
Sent: Monday, December 9, 2024 11:00 AM
To: Ryan Insana <rinsana@townofelkton.com>
Subject: Message from KM_C3350i

Ryan Insana

From: Flock Safety Support <support@flocksafety.com>
Sent: Tuesday, December 10, 2024 12:23 PM
To: Ryan Insana
Subject: We have rescheduled!



Due to a scheduling conflict, your upcoming Flock Safety appointment for F#001 340 @ Elkmont Dr NB has now been rescheduled. Your new appointment date is 12/13/2024.

We apologize for the inconvenience and thank you for your understanding.

Have questions? Check out the FAQs on our website! - [FAQs](#)
Or you can always email us at support@flocksafety.com and we'll get back to you as soon as possible.



Ryan Insana

From: Charmissha Hamlin <charmissha.hamlin@flocksafety.com>
Sent: Monday, November 25, 2024 2:25 PM
To: Alyssa Haray
Cc: Ryan Insana; Brandon Williams; Michael King
Subject: Re: Flock Safety <> Elkton PD <> Partnership Kick Off

Good afternoon,

I appreciate you taking 15-20 min from your busy schedule to speak with your Flock team. As mentioned on our call, once I receive the signed permission letters, your locations will be ready for installation. Your Falcon will be scheduled within the next week or so. Currently, we are experiencing scheduling delays with all Long Range and Condor cameras due to inventory delays. We are working diligently to move scheduling timelines up. I will keep you updated on timelines and check in every 3 weeks (or sooner) with updates.

As discussed, here is the Deployment Tracker [\[link\]](#) , It is helpful for seeing where your projects currently stand and when they are scheduled for installation

I am looking forward to working with you and if you have any questions, please do not hesitate to contact me.

Thank you,

Charmissha Hamlin



Project Manager

 404.549.5545  flocksafety.com

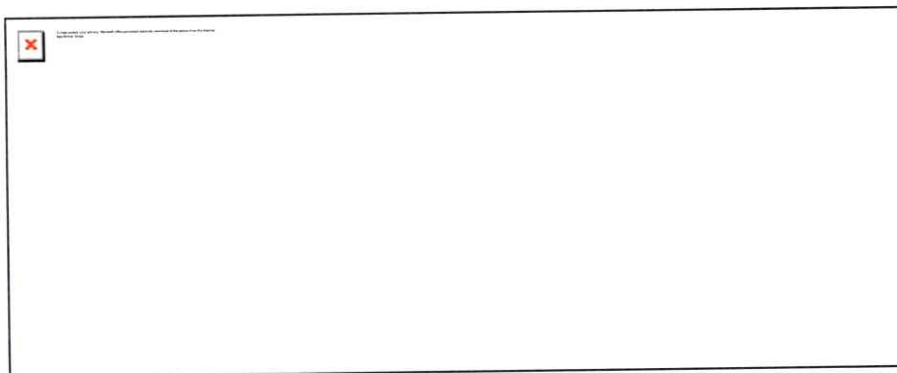

On Mon, Nov 18, 2024 at 12:14 PM Alyssa Haray <alyssa.haray@flocksafety.com> wrote:

Hi Sergeant,

Perfect, thank you! We look forward to meeting. If you need anything before that please let us know.

Best,
Alyssa

On Mon, Nov 18, 2024 at 11:04 AM Ryan Insana <rinsana@townofelkton.com> wrote:

Hi Alyssa,

I'm good for the 25th at 2pm.

Sergeant Ryan M. Insana

Explosive K9 Handler

Town of Elkton Police Department

173 W. Spotswood Ave.

Elkton, VA 22827

Cell: 540-435-2053

Office: 540-298-9441

Fax: 540-298-9499



From: Alyssa Haray <alyssa.haray@flocksafety.com>
Sent: Monday, November 18, 2024 10:25 AM
To: Brandon Williams <brandon.williams@flocksafety.com>
Cc: Michael King <mking@townofelkton.com>; Ryan Insana <rinsana@townofelkton.com>
Subject: Re: Flock Safety <> Elkton PD <> Partnership Kick Off

Hi Chief King & Sergeant Ensana,

Hope you had a great weekend!

Please let us know if the times available to book [here](#) don't work for you, we can send over times if that's easier. We're looking forward to getting your onboarding with Flock started!

Let us know if you have any questions, as Brandon said, we're excited to partner together!

Stay Safe,

Alyssa

On Wed, Nov 13, 2024 at 10:19 AM Brandon Williams <brandon.williams@flocksafety.com> wrote:

Chief King & Sergeant Ensana,

We are extremely excited to get our partnership kicked off.

I wanted to introduce you to your Customer Success Manager Alyssa who will be the main point of contact throughout the onboarding/installation process.

To get things rolling, we'd love to schedule a kick off call to discuss the following...

- Introduce you to our amazing team who will be your go-to partners throughout this process.
- Go over the installation process and timelines to ensure we're all aligned.
- Confirm your goals and objectives with our product to tailor our approach for the best results.

Below is a link to Alyssa's upcoming availability for you to select a time/date that works best for you.

[Book Time Here](#)

Let me know if there are any questions and again we are extremely excited to be partnering together!

--

Brandon Williams



Territory Sales Manager, Local Markets

 flocksafety.com

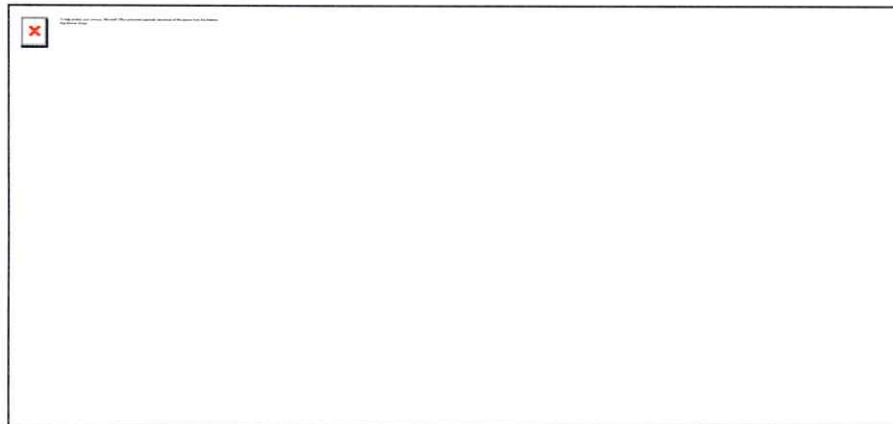



Alyssa Haray
Customer Success Manager



 470-697-1622  flocksafety.com

Join our team for a live training session!

- [Monday 11am ET / 8am PT – General User Training](#)
- [Wednesdays 3pm ET / 12pm PT – General User Training](#)
- [Tuesdays 12pm ET / 9am PT – Admin Training](#)
- [Thursdays 3pm ET / 12pm PT – Admin Training](#)

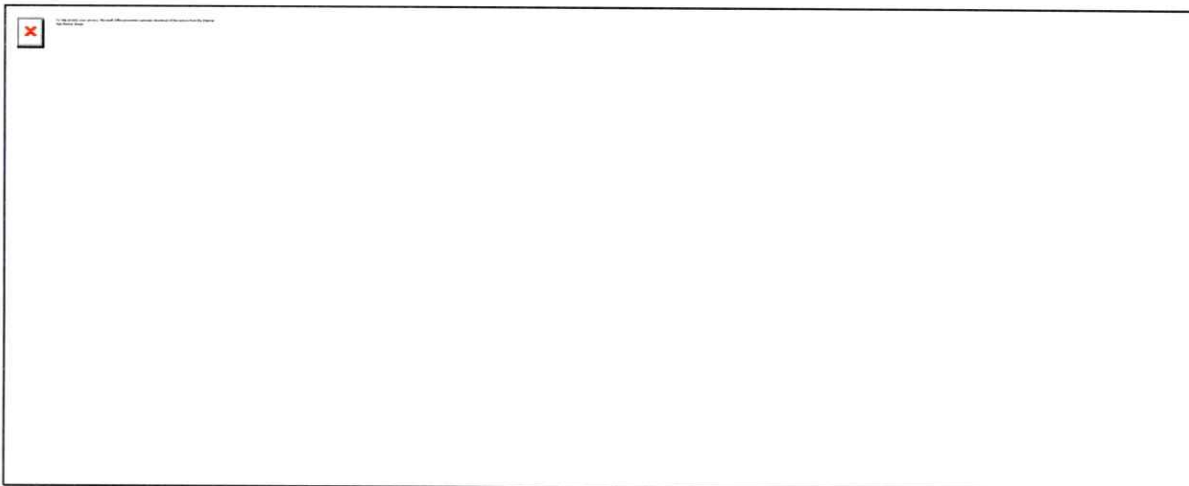



Alyssa Haray
Customer Success Manager



 470-697-1622  flocksafety.com

Join our team for a live training session!

[Monday 11am ET / 8am PT – General User Training](#)

[Wednesdays 3pm ET / 12pm PT – General User Training](#)

[Tuesdays 12pm ET / 9am PT – Admin Training](#)

[Thursdays 3pm ET / 12pm PT – Admin Training](#)

